



ORAC[®]
D E C O R

Reflecting
your
Imagination

Welcome to our World of Imagination



Guy, Laurence & Yves Taillieu

it

Benvenuti nel meraviglioso mondo di ORAC[®]

Orac[®] è il riferimento internazionale per la decorazione in 3D di alta qualità, in continua innovazione nell'ambito della tecnologia, dei materiali e del design. Il risultato è una collezione completa realizzata da e per gli appassionati di decorazione.

I professionisti con spirito creativo ne apprezzano l'innovazione e la facilità di installazione per creare spazi unici e di tendenza. La collezione spazia dai battiscopa e profili per l'illuminazione indiretta alle cornici multifunzionali e gli elementi decorativi. Soluzioni di qualità, moderne, funzionali e decorative.

Con Orac[®] trasformate ogni spazio in un luogo unico, in sintonia con il vostro stile e la vostra personalità, senza alcun limite creativo.

Benvenuti nel nostro mondo.

ro

Bine ati venit in lumea de vis a ORAC®

Orac® este standardul international pentru ornamente 3D de mare calitate, inovand in mod constant in tehnologie, materiale si design. Rezultatul este o colectie cuprinzatoare si completa de si pentru profesionisti pasionati, cu spirit creativ care apreciaza inovatia si calitatea produselor care sunt usor de instalat, si le permit sa creeze spatii inspirate si unice. Colectia cuprinde produse de la plinte si scafe de lumina indirecta la profile multifunctionale si cornise cu adevarat caracter. Solutii contemporane care sunt si functionale si decorative in acelasi timp.

Cu Orac® poti face fiecare spatiu unic, adecvat stilului si personalitatii tale, fara limite de creativitate.

Bine ati venit in lumea noastra.

en

Welcome to the dream world of ORAC®

Orac® is the international standard for quality 3D ornaments, innovating constantly in technology, materials and design. The result is a comprehensive and complete collection by and for passionate professionals. Creative professionals who appreciate innovation and quality products that are easy to install, enabling them to create inspiring and unique spaces. From skirting boards and indirect lighting profiles to multifunctional profiles and cornice mouldings with real character. Contemporary quality solutions that are both functional and decorative.

With Orac® you can make every room unique, entirely in line with your style and personality, without any creative restrictions.

Welcome to our world.

cz

Vítejte ve světě snů společnosti ORAC®

"Orac® je mezinárodním standardem v oboru kvalitních 3D dekorací a přináší trvale inovace v oblasti technologií, materiálů a designu. Výsledkem je komplexní a kompletní kolekce vytvořená jak s pomocí zanícených profesionálů, tak i právě pro ně. Pro kreativní profesionály, kteří oceňují inovace a kvalitní produkty, které se snadno instalují a umožní jim vytvořit inspirativní a unikátní prostory. Od podlahových lišt a nepřímého osvětlení po multifunkční profily a stropní lišty s opravdovým charakterem. Kvalitní moderní řešení, která jsou současně funkční i dekorativní.

S pomocí produktů Orac® můžete každý prostor vytvořit jako jedinečný, ve shodě s vaším stylem a osobností, bez jakýchkoli omezení ohledně kreativity.

Vítejte v našem světě.

pt

Bem vindos ao mundo dos sonhos da ORAC

Orac® é uma referência internacional para decorações em 3D de grande qualidade, inovando constantemente em novos produtos, utilizando a mais recente tecnologia, materiais de qualidade e design inovador. O resultado é uma ampla coleção completa desenhada por e para profissionais apaixonados, com espírito criativo que apreciam produtos inovadores, de qualidade e de fácil instalação. Uma coleção que permite a criação de espaços únicos e inspiradores, desde rodapés e sancas de iluminação indireta a perfis multifuncionais e sancas com personalidade. Soluções modernas e de qualidade superior, mas também funcionais e decorativas.

Com Orac®, poderá tornar qualquer espaço em algo único. Totalmente em conformidade com o seu estilo e personalidade, sem limites de criatividade.

Bem-vindo ao nosso mundo.

Reflecting
your
Imagination

ORAC®
DECOR





Antonio

Create a Ray of Light

Our Design Favorites

2003

Myline



C353
p. 82

Jacques Vergracht

2012

Golf



P3071
p. 67

Ulf Moritz

2009

Infinity



C990
p. 88

Xavier Donck

2009

High Heels



SX156
p. 116

Xavier Donck

2011

Wave



C364
p. 121

Pierre Daems
Red Dot Design Award 2014

2012

Scala



G71
p. 71

Ulf Moritz

2012

Shade



C371
p. 66

Ulf Moritz

2011

Heritage



C343
p. 90

Guy Taillieu

2011

Antonio



C374
p. 68

Ulf Moritz

Content

10 Inspiring Interiors

62 Product Overview

64 Ulf Moritz Collection

80 Cornice Mouldings

100 Panel Mouldings

112 Skirting

118 Indirect Lighting

126 Deco Elements

148 Adhesives & Accessories

154 Project and Exterior Info

156 Technical Info

it

10 Proposte d'interni

62 Sommario Prodotti

64 Ulf Moritz Collection

80 Cornici Soffitto

100 Cornici Parete

112 Battiscopa

118 Illuminazione Indiretta

126 Elementi Decorativi

148 Collanti e Accessori

**154 Progetti &
Applicazioni all'esterno**

156 Informazioni tecniche

ro

10 Ghid de inspiratie

62 Lista de produse

64 Ulf Moritz Collection

80 Cornise

100 Brauri

112 Plinte

118 Iluminat Indirect

126 Elemente Decorative

148 Adezivi si Accesorii

**154 Contract &
Aplicatii la exterior**

156 Informatii tehnice

cz

10 Inspirativní interiéry

62 Přehled produktů

64 Ulf Moritz Collection

80 Stropní Lišty

100 Lemovací Lišty

112 Podlahové Lišty

118 Nepřímé Osvětlení

126 Dekorativní Prvky

148 Lepidla a příslušenství

**154 Smluvní spolupráce &
Applikace v exteriéru**

156 Instalace

pt

10 Interiores inspiradores

62 Visão geral do produto

64 Ulf Moritz Collection

80 Sancas

100 Perfis

112 Rodapés

118 Iluminação Indireta

126 Elementos Decorativos

148 Colas e acessórios

**154 Projetos &
Aplicações Exteriores**

156 Informações técnicas

it

La realizzazione di motivi e linee grafiche utilizzando elementi e profili eleganti e semplici dona una nuova dimensione agli ambienti del Bed and Breakfast. I colori chiari delle pareti e il battiscopa di grande impatto della sala da pranzo evocano la Scandinavia come la immaginiamo: pura, essenziale ed elegante.

ro

Folosind profile si elemente simple si drepte, linii si modele grafice, dau interiorului acestor camere de hotel un plus de eleganta. Tonurile deschise ale peretilor si plintele inalte din camera de luat masa, vopsite in aceeasi culoare ca si podeaua, dau camerei un ambient clasic scandinav: pur, grafic si elegant.

en

Applying simple, straight profiles and elements, graphic lines and patterns gives the interior of this bed and breakfast that extra touch of visual excitement. The light tones on the walls and the high skirting boards in the dining room, painted in the same colour as the wooden floor, give the room a classic Scandinavian ambience: clean, graphic and stylish.

3

4

1 G77 LILY p. 72

designed by Ulf Moritz



2 G78 LILY p. 72

designed by Ulf Moritz

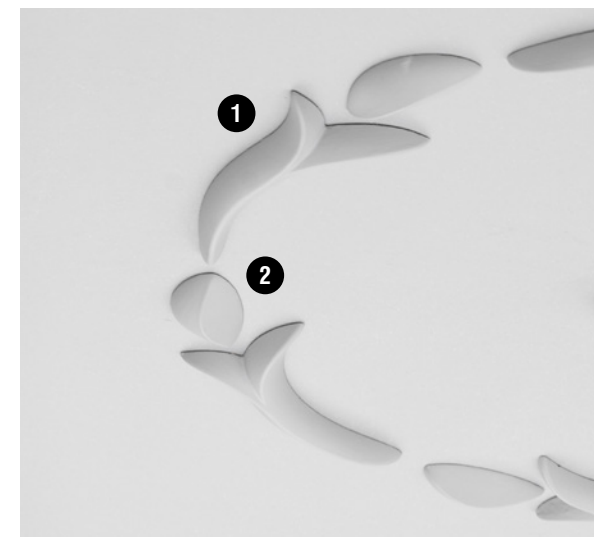

3 CB501 p. 97



4 DX157-2300 p. 114



5 CB503 p. 97



6 PX120 p. 106



7 R66 p. 138



8 DX163-2300 p. 115



9 DX162-2300 p. 106



cs

Použití jednoduchých, rovných profilů a prvků, grafických linií a vzorů, dodává interiéru tohoto penzionu dodatečný nádech vizuálního vzrušení. Světlé tóny na stěnách a vysoké podlahové lišty v jídelně, natřené stejnou barvou jako dřevěná podlaha, dodávají místnosti klasický skandinávský vzhled: čistý, výtvarný a stylový.

pt

O uso de elementos e formas simples, lisos assim como padrões e linhas gráficas, proporciona ao interior deste hostel um toque adicional de emoção visual. As cores claras das paredes e rodapés altos na sala de jantar, pintado da mesma cor que os pisos de madeira dão ao espaço uma sensação de ambiente escandinavo clássico: limpo, gráfico e elegante.

“Clean, graphic lines – pure Scandinavian style”

Vemdalen
— SE

Hölm





Hölm





❶ R08 *p. 136*







❷ CB503 *P. 97*



Multi-Functionals

DX157-2300 | DX157F
 DX162-2300
 DX163-2300
 DX168-2300

<p>❸ DX157-2300 DX157F <i>p. 107</i></p> 	<p>❹ DX162-2300 <i>p. 106</i></p> 
<p>❺ DX163-2300 <i>p. 107</i></p> 	<p>DX168-2300 <i>p. 116</i></p> 

Artson

Cranleigh
— UK



it

In questa sala, la tradizione inglese è stata rivisitata in modo contemporaneo. I riquadri alle pareti formano un motivo classico e le cornici asimmetriche creano una suggestiva illusione ottica. Questo ambiente è la dimostrazione che con la combinazione di diverse cornici fra loro si può ottenere un effetto maestoso.

ro

In această camera este redat "stilul englezesc" într-o manieră modernă. Panourile de pe perete sunt aranjate într-un model original, iar cornișă asimetrică impozantă creează o iluzie optică. Acest interior demonstrează faptul că putem crea cu succes un efect maiestuos cu profile masive.

en

English Heritage is recreated in a modern manner in this room. The framed panels on the wall are arranged in an original pattern, and the imposing asymmetrical cornice moulding creates an optical illusion. This interior shows that a grand style with strong mouldings can be enormously successful.

es

V této místnosti je v moderní podobě obnoveno anglické dědictví. Orámované panely na stěně jsou uspořádány originálním způsobem a působivé asymetrické stropní lišty vytvářejí optickou iluzi. Tento interiér ukazuje, jak úspěšné může být kombinace grandiózního stylu s výraznými lištami.

pt

Esta sala recria o "Património Inglês" a partir de uma perspectiva moderna. Os quadros na parede estão dispostos seguindo um padrão original, enquanto a imponente sanca assimétrica cria uma ilusão de ótica. Este interior confirma que um magnífico estilo com sancas exuberantes podem tornar-se um grande sucesso.



❶ C344 HERITAGE p. 91



❷ P8030 p. 102



❸ P8020 p. 103



❹ P4020 p. 102



❺ SX118 p. 116





❶ P8020 p. 103



❷ P4020 p. 102



Artson

*“Grand style:
a great success”*

C341 M

P. 84

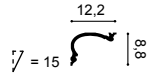

C342 L

P. 87



C343 XL

p. 90

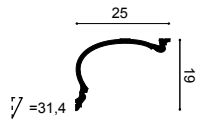

3 C344 XXL

p. 91

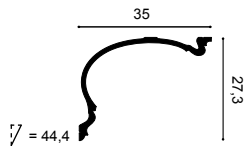

4 DX170-2300

p. 128

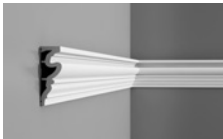

5 D330LR

p. 128

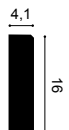

C341 M
C342 L
C343 XL
C344 XXL
DX170-2300
D330LR

**The
Heritage
Collection**



Das
Tegernsee
Hotel

❶ PX120 p. 106



❷ P8020 p. 103



❸ PX103 p. 106



❹ SX137 p. 115



❺ CX124 p. 94

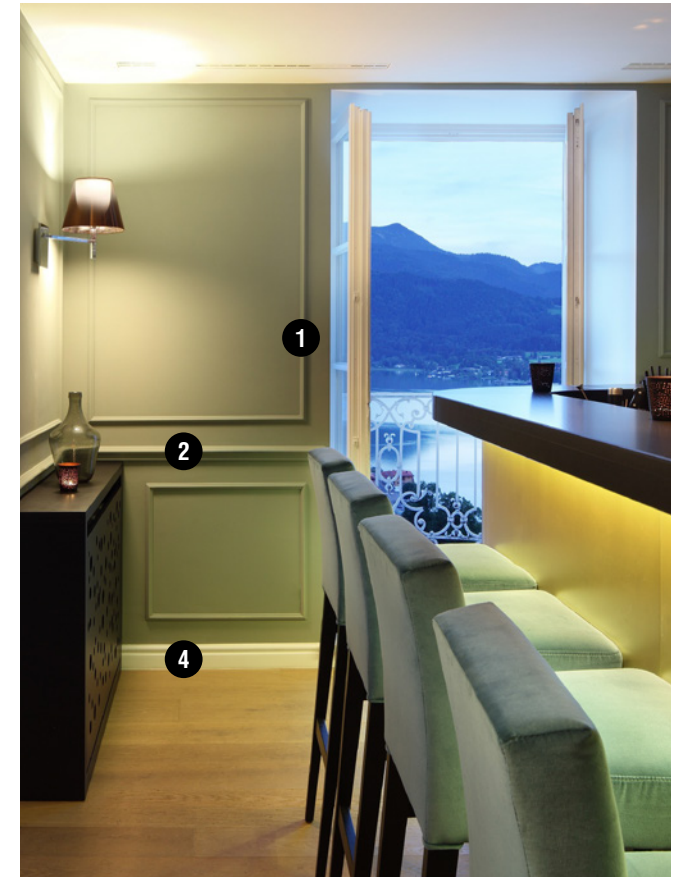

Tegernsee
— DE

*"A room
with a view"*



Northsea Penthouse

Oostende
— BE



“Sometimes it complements the surroundings, sometimes it emphasizes them and sometimes it quietly merges into them – that is the essence of architecture”

it

L'obiettivo era semplice: ricreare all'interno l'atmosfera riposante evocata dalla natura e dal mare. Le cornici aggiungono carattere agli interni senza essere invadenti, l'illuminazione indiretta dona un nuovo senso di luce e spazio a questo appartamento situato sulla costa belga.

ro

Obiectivul a fost de a aduce în interior calmul indus de natura și mare. Profilele montate fara a fi foarte evidente, si scafa de lumina indirecta dau un caracter luminos si spatios acestui apartament de pe coasta belgiana.

en

The task was to bring the restful mood of nature and the seashore inside. The mouldings add to the interior without being conspicuous, and the indirect lighting gives this flat on the Belgian coast a light and roomy feel.

es

Úkolem bylo přenést dovnitř uklidňující náladu přírody a mořského pobřeží. Lišty doplňují interiér, aniž by byly nápadné, a nepřímé osvětlení dodává tomuto bytu na belgickém pobřeží lehkost a prostornost.

pt

O objetivo era trazer a paz que se sente na natureza e do mar para dentro. As sancas são integradas no interior sem ser perceptível, enquanto a iluminação indireta transmite ao piso da costa belga uma sensação de amplitude de espaço e luminosidade.

1 C357 STRAIGHT p. 120

designed by
Jacques Vergier
licht

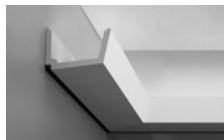

2 DX157-2300 p. 114



3 C354 p. 82

designed by
Jacques Vergier
licht



4 DX163-2300 p. 115





1 C990 INFINITY *p. 90*

designed by Xavier Donck



2 SX156 HIGH HEELS *p. 116*

designed by Xavier Donck



3 CX126 *p. 95*



4 C362 CURVE *p. 121*

designed by Pierre Dumas



Northsea Penthouse



Den Haag
— NL

Clinic 28



it

L'antico splendore degli interni di questa imponente villa a L'Aia torna a rivivere grazie ai battiscopa, ai riquadri alle pareti e alle cornici a soffitto. In questa Clinica estetica, la bellezza trova la sua piena espressione in un ambiente caldo e intimo.

ro

Aura autentică a interiorului acestei vile impunătoare din Haga a fost restaurată prin montarea plintelor, a panourilor și a corniselor. În această clinică de cosmetică, frumusețea își găsește cea mai înaltă expresie într-un mediu cald și prietenos.

en

The authentic aura of the interior of this stately villa in The Hague has been restored by fitting skirting boards, framed panels and cornice mouldings. In this cosmetic clinic, beauty finds its full expression in a warm, familiar surroundings.

es

Autentická aura interiéru této majestátní vily v Haagu byla obnovena instalací podlahových lišt, orámovaných panelů a stropních lišt. Na této kosmetické klinice našla krásu své plné vyjádření v teplém, rodinném prostředí.

pt

O uso de rodapés, perfis e sancas permitiram restaurar o verdadeiro encanto genuíno do interior desta majestosa mansão em Haia. Nesta clínica de estética, a beleza encontra a sua plena expressão, num ambiente familiar e acolhedor.



1 P8030 p. 102



2 P8020 p. 103



3 P8050 p. 105



4 SX118 p. 116



Clinic 28



1 R40 *p. 139*



2 P8030 *p. 102*



3 C217 *p. 85*





“A perfect reflection of the true and natural beauty of mouldings”

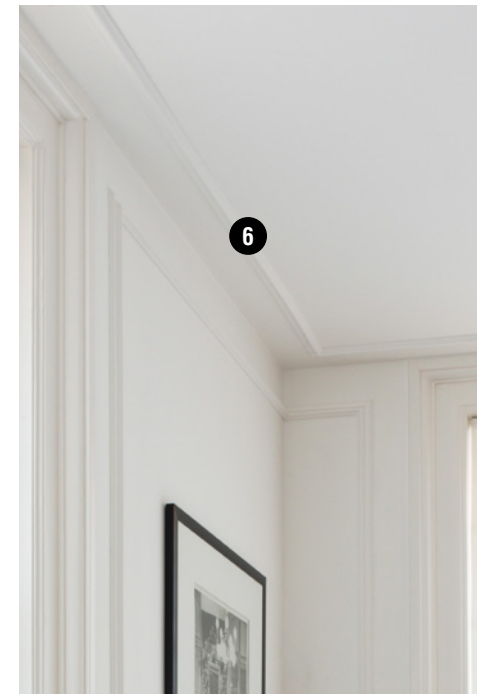

4 P8050 p. 105



5 SX118 p. 116



6 PX103 p. 106





St. Petersburg
— RU

Metiendovivendum

1 SX118 p. 116



2 P8050 p. 105



3 D170 p. 132



4 P8030 | P8030F p. 102



5 P8020 | P8020F p. 103



6 P8050 | P8050F p. 105



7 SX118 | SX118F p. 116



8 C307 p. 90



“Rooms that breathe history”

— Sigisbert Engelbosch,
Interior Designer





Manoir Fleuriri

Bordeaux
— FR





it

Questa ambientazione è la prova che il ritorno allo stile barocco non è necessariamente sinonimo di eccesso. Cornici, angoli ed elementi decorativi ispirati al passato creano un insieme di linee e ombre, senza farsi troppo notare.

en

Baroque is back, but that does not necessarily mean artistic excess – as this interior demonstrates. The decorative mouldings and corner features, inspired by the past, generate an array of lines and shadows without being obtrusive.

ro

Acest interior este dovada ca stilul Baroque a revenit, dar aceasta nu este neaparat sinonimul excesului. Profilele decorative si elementele de unghi, inspirate din trecut, genereaza un joc de linii si umbre aproape imperceptibil.

es

Baroko je zpět, ale neznamená to nutně umělecký exces – důkazem budiž tento interiér. Dekorativní lišty a rohové prvky inspirované minulostí generují řadu linií a stínů, aniž by přitom obtěžovaly.

pt

O barroco está de volta, embora - tal como evidenciado neste interior- não implica necessariamente um excesso artístico. As sancas e os elementos de canto decorativos, inspirados no passado, geram um conjunto de linhas e sombras quase imperceptível

1 C338A BA'ROCK p. 89



2 C338B BA'ROCK p. 89



3 P3020+P3020A p. 109

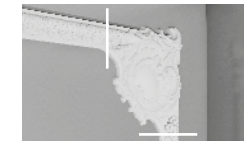

4 P8040 p. 104



5 P8020 p. 103



6 D62 p. 136



7 P8050 p. 105



8 SX118 p. 116



9 C338 p. 89



1 DX162-2300 p. 106



2 C353 p. 82



Designed by
Jacques Vergnaud

Lan Lan

Madrid
— ES

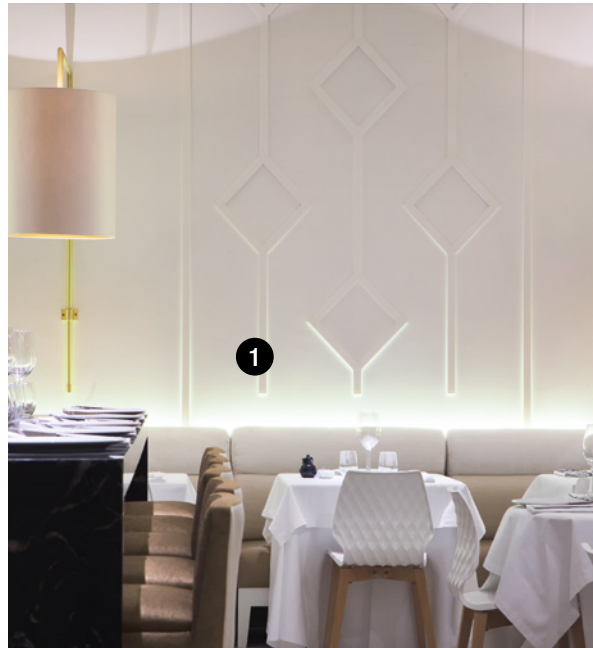

“All it takes is one profile and a good deal of creativity to get to an extraordinary result”



❶ C901 p. 125



❷ P8030 p. 102



BDBA

*“Fashion and interior
design: a perfect fit”*



Berto

Waregem — BE

it

L'interno del ristorante stellato Berto, completamente rinnovato, riflette il carattere della sua cucina: classica, con tocchi moderni. Lo stile minimalista e completamente bianco è movimentato dai battiscopa e dai profili lineari e puliti; l'illuminazione indiretta crea la giusta atmosfera.

ro

Interiorul renumitului restaurant Berto reflecta caracterul bucatariei sale: clasic cu o tenta moderna. Baza eleganta in stil alb, minimalist, este subliniata de plintele si cornisele cu linii simple si clare, in timp ce lumina indirecta creeaza o atmosfera perfecta.

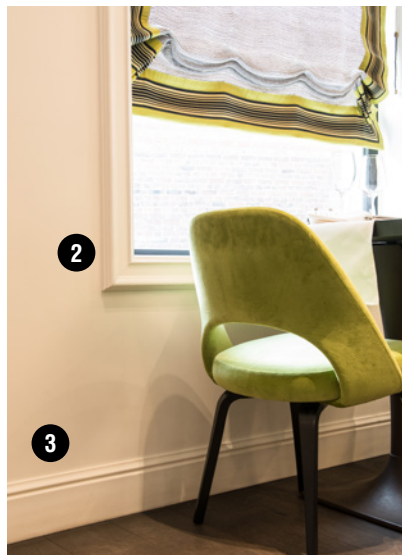
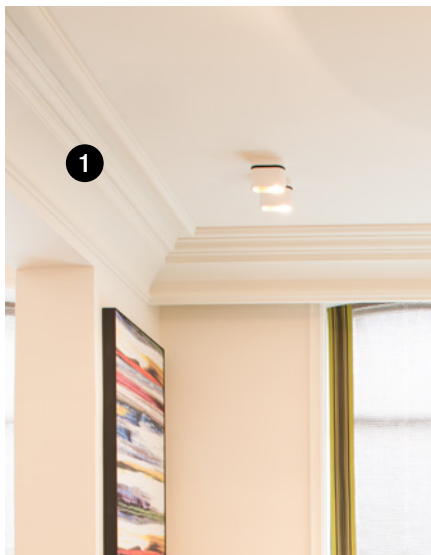



“Orac Decor® profiles add extra flavor to clean and white spaces”

en

The interior of the renowned Berto restaurant reflects the character of the cuisine: classical with a modern touch. The perfectly styled base in taut, clean white is given extra emphasis by skirting-boards and cornice mouldings with simple, clean lines, while the indirect lighting creates a suitable ambience.

es

Interiér renovované restaurace Berto odráží charakter kuchyně: klasická s moderním nádechem. Dokonale stylový základ v čisté bílé barvě je zvýrazněn podlahovými a stropními lištami s jednoduchými, čistými liniemi, a nepřímé osvětlení vytváří vhodnou atmosféru.

pt

O interior do reconhecido restaurante Berto reflete a personalidade da sua cozinha: clássica com um toque moderno. O estilo imaculado da sala, na cor branco puro e intenso, adquire maior destaque graças aos rodapés e sancas de linhas simples e limpas. Enquanto isso, a iluminação indireta ajuda a criar um ambiente ideal.

1 C336 *p. 91*



2 DX121-2300 *p. 104*



3 SX118 *p. 116*



4 R09 *p. 137*



5 C217 *p. 85*



6 C901 *p. 125*



7 R40 *p. 139*



Eyes

Nights Only

Kortrijk
— BE





“Raw meets design: ORAC hotel make-over”

1 C374 ANTONIO p. 68



2 C373 ANTONIO p. 68

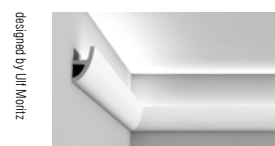

3 C991 CURTAIN PR. p. 70



4 P3070 RADIUS p. 67

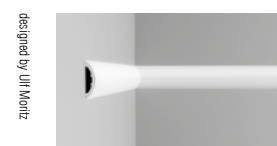

5 C371 SHADE p. 66



7 FOCUS R70 p. 71, 138



6 SX156 HIGH HEELS p. 116





Grayson Estate

The Hamptons
— USA

1 SX118 p. 116



2 C334 p. 88



3 C333 p. 86



4 C331 p. 83





1 P9010 p. 104



2 P8020 p. 103



3 SX118 p. 116



4 C334 p. 88



5 C370 CLOUD p. 67



it

Dall'eleganza pura alla stravaganza: in un unico progetto tutte le possibilità sono aperte. Ogni ambiente racconta la sua storia. L'illuminazione indiretta genera un livello aggiuntivo tra le pareti e il soffitto, e la cornice "Cloud" di Ulf Moritz crea quasi letteralmente la luce sopra le tende scure.

ro

De la eleganta la extravaganta: in acest proiect unic, toate registrele sunt deschise. Fiecare camera isi spune povestea. Iluminatul indirect genereaza un nivel suplimentar intre pereti si tavan, iar profilul "Norul" lui Ulf Moritz aproape literal creeaza lumina deasupra perdelelor intunecate.

en

From understated elegance to extravagance: all the stops are pulled out in this unique project. Every room tells its own story. The indirect lighting generates an extra level between the walls and the ceiling, and the Ulf Moritz "Cloud" moulding almost literally creates light above the dark curtains.

es

Od umírněné eleganci k extravaganci: v tomto jedinečném projektu stojí všechny zastávky za to. Každá místnost vypráví svůj vlastní příběh. Nepřímé osvětlení generuje další linii mezi stěnami a stropem a lišta Cloud (Oblak) od Ulfa Moritze vytváří doslova světlo nad tmavými závěsy.

pt

Da elegância á extravagância, este projecto único aproveita todos os estilos. Cada quarto tem sua própria história. A iluminação indireta resulta num nível extra entre as paredes e o teto, enquanto a sanca "Cloud" Ulf Moritz cria literalmente cria iluminação acima das cortinas escuras.

Grayson Estate



2

1

2



it

La profondità è la parola chiave in questo tunnel rosso. Le linee pulite convergenti - che incorniciano anche la porta - e l'illuminazione indiretta del soffitto trasformano questo corridoio buio in un tunnel luminoso. Il senso di profondità è accentuato e richiama l'attenzione verso l'orizzonte.

ro

Adancimea este cuvântul cheie în acest tunel roșu. Linile drepte convergente, care înconjoară atât usa cât și lumina indirectă de pe tavan, transformă acest pasaj întunecat într-un tunel luminescent. Adancimea este accentuată și atrage atenția de la departare.

en

Depth is the keyword in this red tunnel. The straight converging lines, which also surround the door and the indirect lighting on the ceiling transform this dark passageway into a luminescent tunnel. Depth is emphasized and draws attention to the distant view.

cs

V tomto červeném tunelu je hloubka klíčovým slovem. Rovné sbíhavé linie, které rovněž obklopují dveře, a nepřímé osvětlení na stropě transformují tento tmavý průchod ve svítící tunel. Jeho hloubka je zvýrazněna a přitahuje pozornost k pohledu do dálky.

pt

A profundidade é a palavra chave para este túnel vermelho. As linhas simples convergentes, que também envolvem a porta e a iluminação indireta do teto transformam este corredor escuro num túnel luminescente. A sensação de profundidade é acentuada e conduz o olhar para o infinito.

2 DX168-2300 p. 129

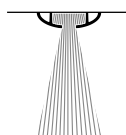

Antonio Lighting Inspiration

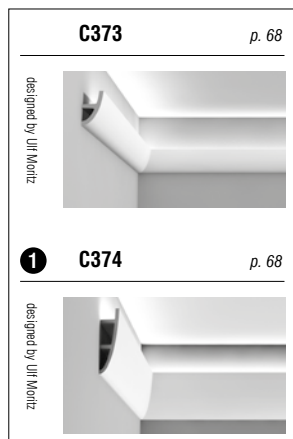

The Red

Milano
— IT

“Using ORAC’s versatile products we’ve recreated a classic style”

— Beatriz Silvera,
Spanish Interior designer

Casa **Madrid** — ES *Decor*





it

Una volta l'anno, tutti i professionisti e gli appassionati di interior design vengono a visitare Casa Decor. Al vecchio edificio è stata data nuova vita, grazie alla combinazione perfetta degli elementi in un risultato sorprendente. Il gioco di colore, di luce e di texture sul soffitto, sulle pareti e anche sull'arredamento è particolarmente valorizzato dalle cornici e dagli elementi Orac Decor®.

ro

O data pe an toti designer-ii profesionisti si entuziasti fac un pelerinaj la Casa Decor. O noua viata ia nastere intr-o cladire veche, cu acest mixt surprinzator ca rezultat. Profilele si elementele decorative Orac Decor® dau o nota speciala prin jocul de culori, lumini si texturi al tavanelor, peretilor, si chiar si a mobilei.

en

Once a year all interior design professionals and enthusiasts make a pilgrimage to Casa Decor. New life is breathed into an old building, with this surprising mix as a result. The Orac Decor® mouldings and elements give a special touch to the play of colour, light and texture on the ceiling, walls, and even the furniture.



1 C336 p. 91



2 C201 p. 85



3 P8030 p. 102



4 SX118 p. 116



5 DX157-2300 p. 107



6 P8020 p. 103



7 F30 p. 140



8 H100 p. 133





cs

Jednou ročně absolvují všichni profesionálové i nadšenci z oboru designu interiérů pouť do Casa Decor. Staré budově byl vdechnut nový život a výsledkem je tato překvapivá směs. Lišty a prvky Orac Decor® dodaly speciální nádech hry barev, světla a struktury na stěnách, stopech a dokonce i nábytku.

pt

Uma vez por ano, todos os profissionais de design de interiores e entusiastas fazem peregrinação à Casa Decor, em Espanha. Um edifício velho e um novo interior são a combinação perfeita para um resultado surpreendente. Sancas e elementos Orac Decor satisfazem a exigência de decoradores e arquitetos de interiores mais prestigiados, adicionando um toque especial no jogo de cores, luzes e texturas nos tetos, paredes e até mesmo nos móveis.

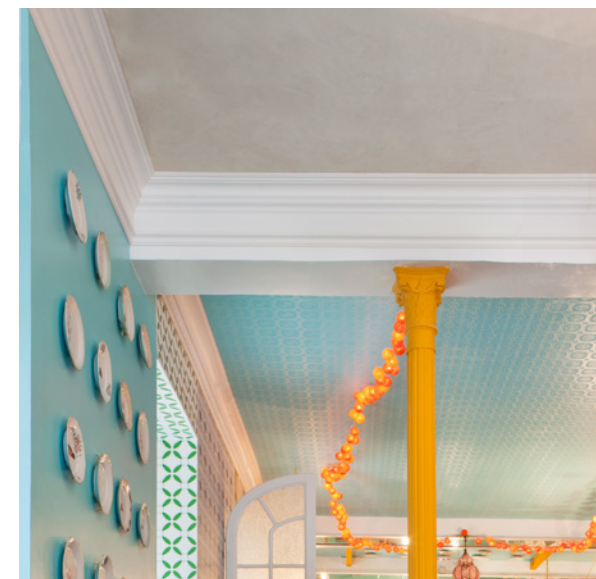

1 C340 p. 91



2 D400 p. 132



3 K200+D320 p. 146

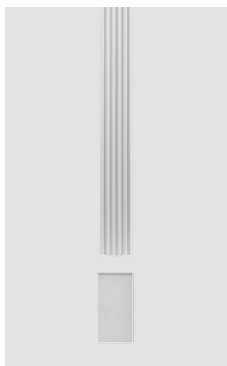

4 P8020 p. 83



5 SX138 p. 116



6 PX103 p. 106



7 PX102 p. 107



8 C217 p. 85



9 SX137 p. 115



Casa Decor



7

8

9

1 C372 FLUXUS p. 66

designed by Ulf Moritz



2 P3071 GOLF p. 67

designed by Ulf Moritz



Rabo | Amsterdam — NL Bank

“The DNA of Orac Decor[®] profiles allowed us to create a homely feeling in a business environment”

— MEMO, Interior Composers

“A living Pinterest, there’s no better way to subscribe this showroom”



Pand

16

Sint-Niklaas
— BE



R CEILING ROSES p. 136



1 C371 SHADE p. 66



designed by Juri Moritz

*"Traditional luxury in a
historic setting"*

't Goude Hoofst

Den Haag
— NL





1 P9010 p. 104



2 P8030 p. 102



3 SX118 p. 116



4 C371 SHADE p. 66



designed by Ulf Moritz

5 G72 SMILE p. 72



designed by Ulf Moritz

6 G73 | G74 CURL p. 72



designed by Ulf Moritz



it

Grazie alla combinazione di diversi profili Orac Decor® e degli originali elementi Ulf Moritz, gli ospiti del più antico albergo de L'Aia vengono accolti in lussuosi ambienti di grande bellezza.

ro

Multumita gamei largi de profile Orac Decor® si a elementelor jucause Ulf Moritz, oaspetiilor celui mai vechi han din Haga gasesc aici lux, opulenta si frumusetete.

en

Thanks to the rich mix of Orac Decor® mouldings and playful Ulf Moritz elements, hotel guests at the oldest inn of The Hague are welcomed in luxury, opulence and beauty.

es

Díky bohaté kombinaci listů Orac Decor® a prvků Ulf Moritze přivítá hosty nejstaršího hotelu v Haagu luxus, bohatství a krása.

pt

Grças à combinação sofisticada de sancas Orac Decor® com os elementos engraçados Ulf Moritz, os hóspedes do hotel mais antigo em Haya são recebidos com luxo, opulência e beleza.

1 P3070 RADIUS p. 67

designed by Ulf Moritz

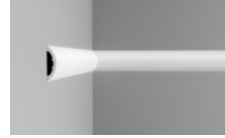

2 C370 CLOUD p. 67

designed by Ulf Moritz



3 P3071 GOLF p. 67

designed by Ulf Moritz



"A cosmopolitan atmosphere thanks to the organic shapes created by Ulf Moritz' profiles"

Roeselare
— BE

Bardò

Pink Eye

Antwerpen
— BE

ORAC
DECOR

3 SX155 p. 155



4 F12 p. 140



1 C217 p. 88



2 DX170-2300 p. 105



1 C371 SHADE p. 66

designed by Ulf Meitz



2 DX163-2300 p. 115



3 C370 CLOUD

designed by Ulf Meitz



5 P3071 GOLF p. 67

designed by Ulf Meitz



4 SX167 DUNE p. 67

designed by Ulf Meitz

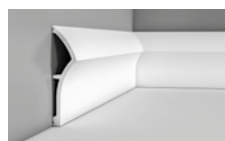

6 R66 p. 138



Big One

Oostende
— BE



P PANEL MOULDINGS 100-111



it

Se desideri essere fonte d'ispirazione nel mondo del design d'interni, è necessario dare il buon esempio. Nello showroom presso la nostra sede è esposta in modo particolarmente sorprendente la collezione completa dei prodotti Orac Decor®.

ro

Dacă doriți să inspirați creativitate în lumea design-ului interior, trebuie să dați un exemplu bun. În showroom-ul de la sediul ORAC, o amplă colecție este pusă în centrul atenției într-un mod surprinzător.

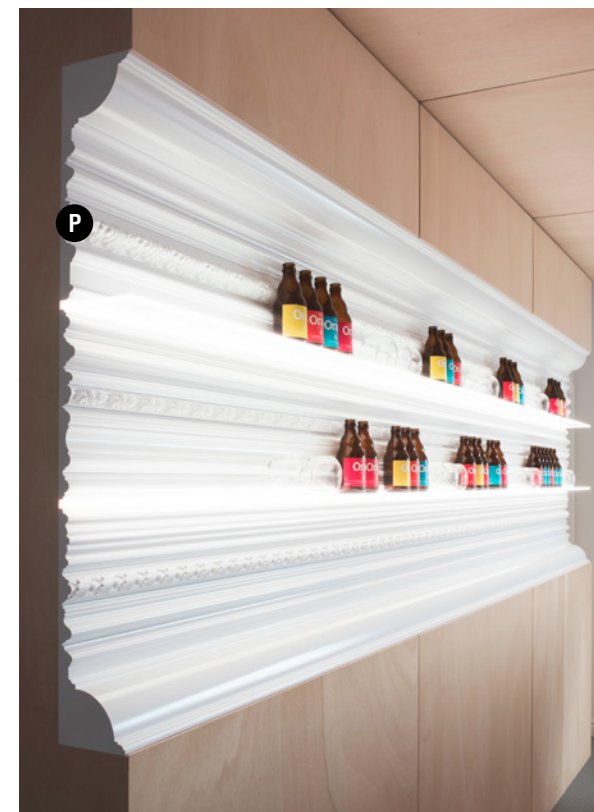

en

If you want to inspire creativity in the interior design world, you have to set a good example. In the showroom at the ORAC head office, the extensive collection takes centre stage in a really surprising way.

es

Pokud chcete ve světě designu interiérů podníit kreativitu, musíte uvést dobrý příklad. V předváděcích prostorách sídla společnosti ORAC zabírá rozsáhlá kolekce centrální prostor skutečně překvapujícím způsobem.

pt

Se deseja inspirar a criatividade no mundo do design de interiores, é necessário dar um bom exemplo. Na sala de exposições, da sede da ORAC em Ostend (Bélgica), a extensa coleção chama a atenção de uma forma verdadeiramente surpreendente.

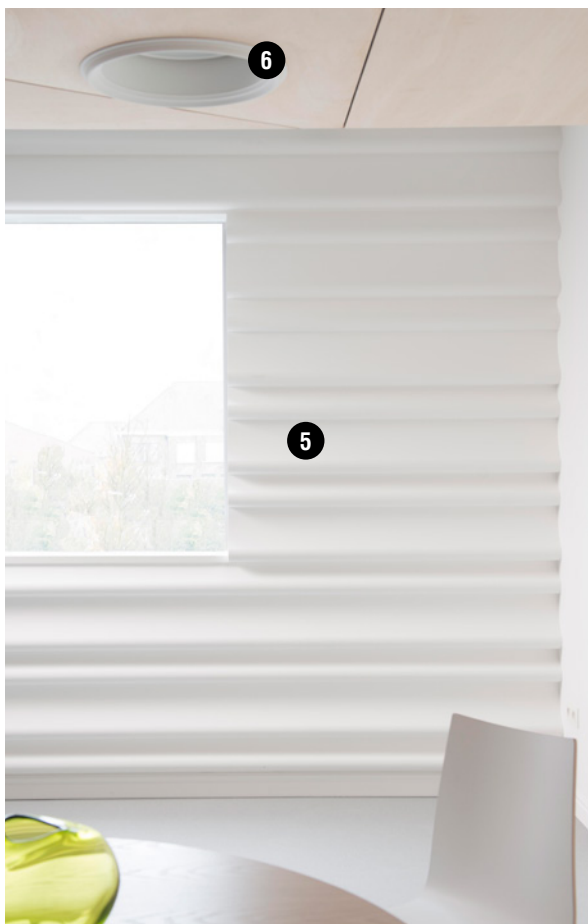

“Show 'm what you've got: the live interpretation of the ORAC identity”



it

Nell'albergo Porters gli ambienti accoglienti e senza tempo sono in perfetta armonia con l'architettura dell'edificio. In ogni stanza le colonne, le cornici e i rivestimenti murali catturano lo sguardo in un modo teatrale.

ro

In Porters Guesthouse, interiorul traditional cald armonizeaza perfect cu arhitectura cladirii. In fiecare camera coloanele, cornisele si tapetul iti atrag atentia intr-un mod aproape teatral.

House of Antwerpen — BE Porters

1 K1002+K1152 p. 144

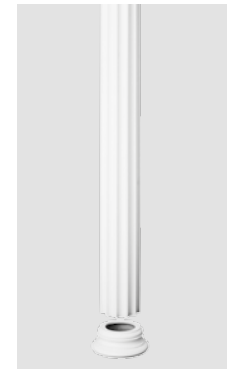

2 C422 p. 89



3 R76 p. 138



2



Pieter Porters



en

In Porters Guesthouse, the traditional warm interior harmonises perfectly with the architecture of the building. In every room columns, cornice mouldings and wall coverings draw your attention in an almost theatrical manner.

cz

V Porters Guesthouse tradiční teplý interiér dokonale ladí s architekturou budovy. Ve všech místnostech přitahují Vaši pozornost sloupy, stropní lišty a výzdoba stěn způsobem téměř divadelním.

pt

Na Porters Guesthouse, o tradicional interior acolhedor combina perfeitamente com a arquitetura do edifício. Em cada sala, colunas, sancas e revestimentos de parede atraem todas as atenções de forma quase teatral.



1 C900 *p. 89*



2 C307 *p. 90*



3 C338B BA'ROCK *p. 89*



4 SX118 *p. 116*



5 P4020 *p. 102*



6 DX121-2300 *p. 104*



7 P7030 *p. 104*



8 P9010 *p. 104*



9 PX103+PX103A *p. 110*



10 P3020A+P3020 *p. 109*



11 K200 *p. 146*



12 D320 *p. 146*



13 D401+D402 *p. 132*

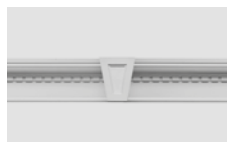

14 D503+D504+D507 *p. 130*



15 M9010L *p. 134*



16 P20 *p. 147*



Reflecting
your
Imagination

ORAC[®]
DECOR





Liberté

Let your Creativity flow

Product Overview

	CORNICE MOULDINGS	PANEL MOULDINGS	SKIRTING BOARDS	INDIRECT LIGHTING	DECO ELEMENTS
	CORNICI SOFFITTO CORNISE STROPNÍ LIŠTY SANCAS	CORNICI PARETE BRAURI LEMOVACÍ LIŠTY PERFIS	BATTISCOPIA PLINTE PODLAHOVÉ LIŠTY RODAPÉS	ILLUMINAZIONE INDIRETTA ILUMINAT INDIRECT NEPŘÍMÉ OSVĚTLENÍ ILUMINAÇÃO INDIRETA	ELEMENTI DECORATIVI ELEMENTE DECORATIVE DEKORATIVNÍ PRVKY ELEMENTOS DECORATIVOS
ULF MORITZ	p.67-70	p.67	p.67	p.66-69	p.71-79
3D DARING DESIGNS	PUROTOUCH [®]	PUROTOUCH [®]	PUROTOUCH [®] DUROPOLYMER [®]	PUROTOUCH [®]	PUROTOUCH [®] DUROPOLYMER [®]
LUXXUS	p.82-91	p.102-105	p.114-117	p.120-125	p.128-148
EXCLUSIVE & STYLISH CONCEPTS	PUROTOUCH [®]	PUROTOUCH [®] DUROPOLYMER [®]	DUROPOLYMER [®]	PUROTOUCH [®]	PUROTOUCH [®] DUROPOLYMER [®]
AXXENT	p.92-96	p.106-108	p.114-117		
HIGH QUALITY INTERIOR SOLUTIONS	DUROPOLYMER [®]	DUROPOLYMER [®]	DUROPOLYMER [®]		
BASIXX	p.97				
BUDGET FRIENDLY DESIGNS	DUROFOAM [®]				

Purotouch[®]

Poliuretano espanso ad alta densità.

Poliuretan de calitate si inalta densitate.

A moulded quality high-density polyurethane.

Tvarovaný, kvalitní, polyuretan s vysokou hustotou.

Produtos de qualidade em poliuretano de alta densidade

Duropolym[®]

Polimero estruso resistente agli urti, formato da una miscela di polistirene ad alta densità.

Un polimer extrudat si rezistent la impact pe baza unui polistiren de inalta densitate.

An extruded and impact-resistant polymer based on a high-density polystyrene.

Lisovaný, mechanicky odolný polymer na bázi hustého polystyrénu.

Polímero extrudido, resistente a impactos, com base numa mistura de poliestireno de alta densidade.

Durofoam[®]

Polimero leggero estruso, formato da una miscela di polistirene di media densità.

Un polimer extrudat usor pe baza unui polistiren de medie densitate.

An extruded lightweight polymer based on a medium-density polystyrene blend.

Lisovaný lehký polymer na bázi středně husté polystyrénové směsi.

Polímero extrudido, leve, baseado numa mistura de poliestireno de média densidade.

ADHESIVES AND ACCESSORIES

COLLANTI E ACCESSORI
ADEZIV SI ACCESORII
LEPIDLA A PŘÍSLUŠENSTVÍ
COLAS E ACESSÓRIOS

p.148-153





it

Ulf Moritz: un marchio di carattere per i tuoi interni. A parete o a soffitto, con illuminazione indiretta o senza, gli elementi di design della collezione offrono un'esperienza in 3D inimitabile. Una combinazione di potenza, grandezza ed eleganza.

en

Ulf Moritz brings movement and dynamics to your interior. The collection of design elements for walls and ceilings, with or without integrated lighting, creates an unparalleled 3D effect. Powerful, imposing and elegant at the same time.

pt

Ulf Moritz traz movimento e dinamismo ao seu interior. Esta coleção de elementos de design, para paredes e/ou tectos, com ou sem iluminação integrada, cria um efeito 3D sem paralelo. Poderosa, intensa, imponente e elegante ao mesmo tempo.

ro

Ulf Moritz aduce miscare și dinamism interiorului. Colecția de elemente de design pentru pereți și tavane, cu sau fără iluminat integrat, creează un efect 3D de neegalat. Puternic, impozant și elegant în același timp.

cz

Ulf Moritz přináší do Vašeho interiéru pohyb a dynamiku. Kolekce dekorativních prvků pro stěny a stropy, s integrovaným osvětlením nebo bez něho, vytváří bezkonkurenční 3D efekt. Výrazné, působivé a současně elegantní.

Ulf Moritz Collection

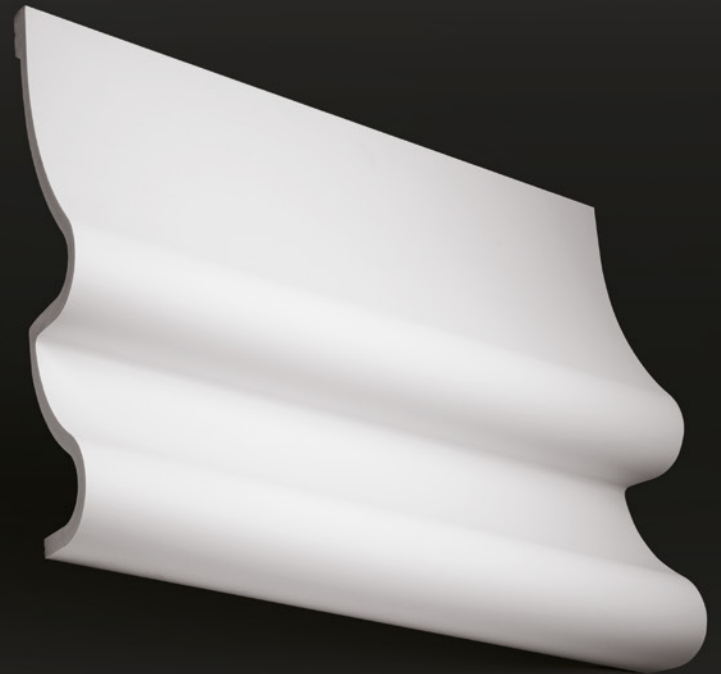

Ulf Moritz Collection



❶ **C374 ANTONIO** p. 68

❷ **C371 SHADE** p. 66



C371 SHADE

200 x 18,5 x 5,8 cm
Purotouch[®]

ULF MORITZ

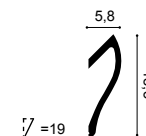

C372 FLUXUS

200 x 28 x 7 cm
Purotouch[®]

ULF MORITZ

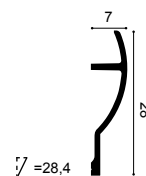



C370 CLOUD

ULF MORITZ

200 x 20 x 16 cm
Purotouch[®]

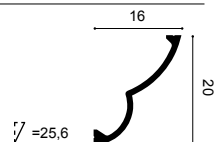

P3071 GOLF

200 x 37,2 x 7,6 cm
Purotouch[®]

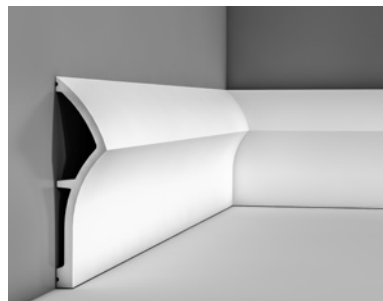

SX167 DUNE

ULF MORITZ

200 x 17,3 x 4,3 cm
Duropolymer[®]

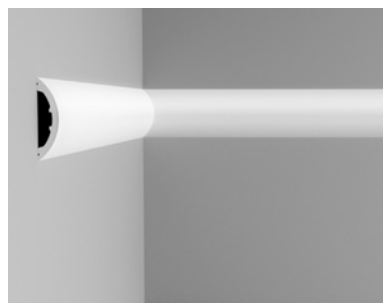
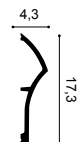

P3070 RADIUS

ULF MORITZ

200 x 12,5 x 3,2 cm
Purotouch[®]

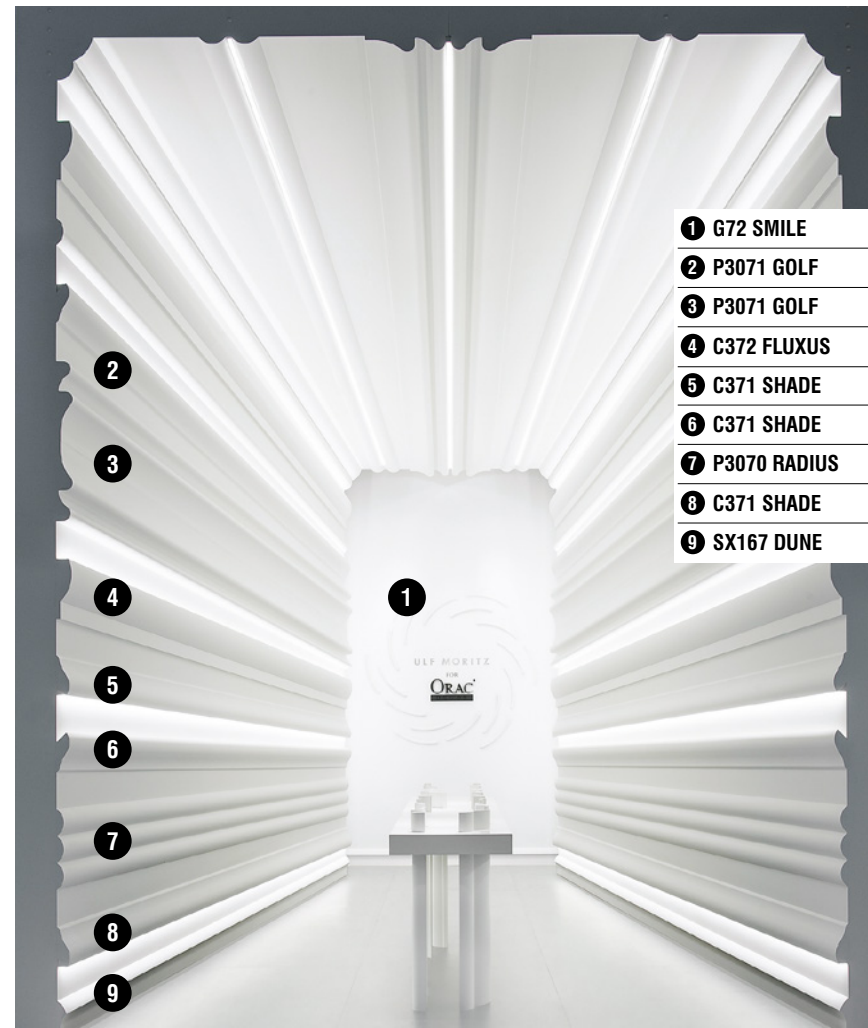

- 1 G72 SMILE p. 72
- 2 P3071 GOLF p. 67
- 3 P3071 GOLF p. 67
- 4 C372 FLUXUS p. 66
- 5 C371 SHADE p. 66
- 6 C371 SHADE p. 66
- 7 P3070 RADIUS p. 67
- 8 C371 SHADE p. 66
- 9 SX167 DUNE p. 67

Ulf Moritz Collection

1 C374 ANTONIO p. 68

2 C991 p. 70



C373 | C373F ANTONIO

200 x 8 x 5 cm
Purotouch[®]

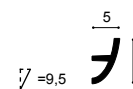

ULF MORITZ

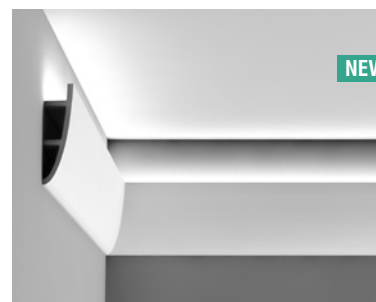

C374 | C374F ANTONIO

200 x 18 x 5 cm
Purotouch[®]

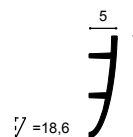

ULF MORITZ

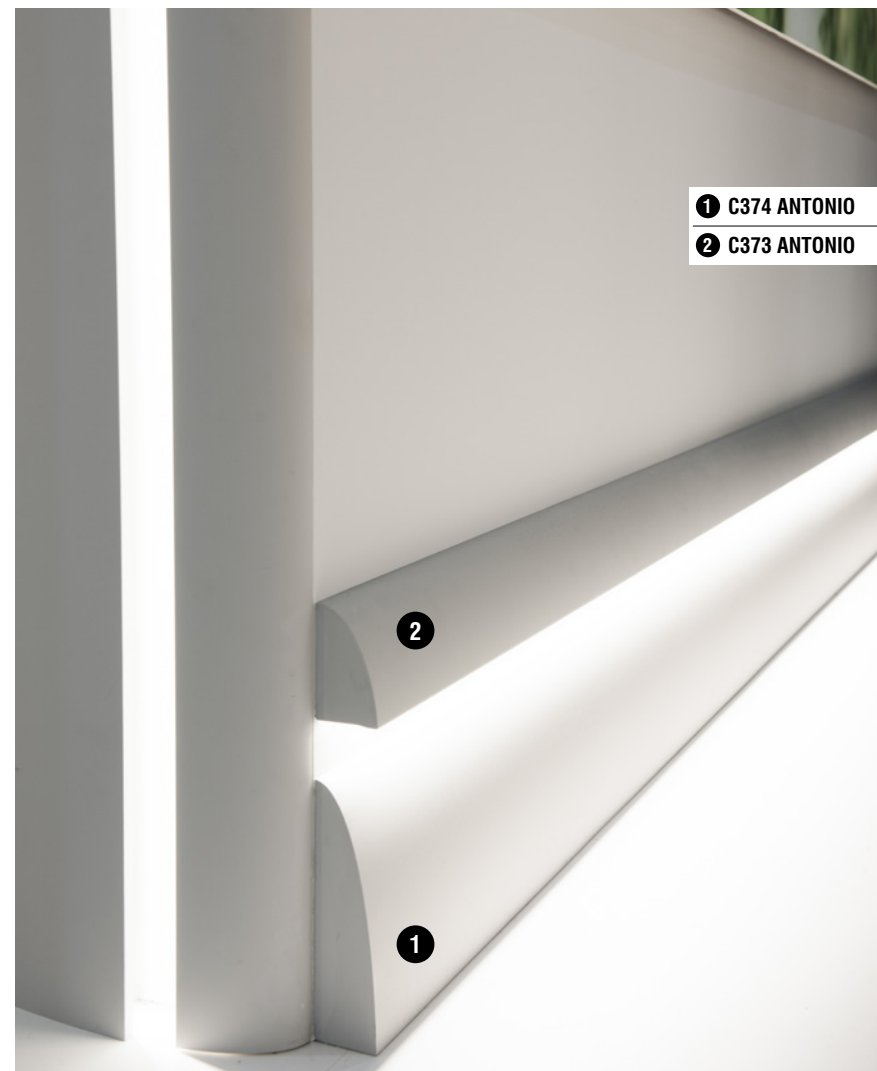

Ulf Moritz Collection



C991 CURTAIN PROFILE

200 x 11 x 14 cm
Purotouch[®]

ULF MORITZ

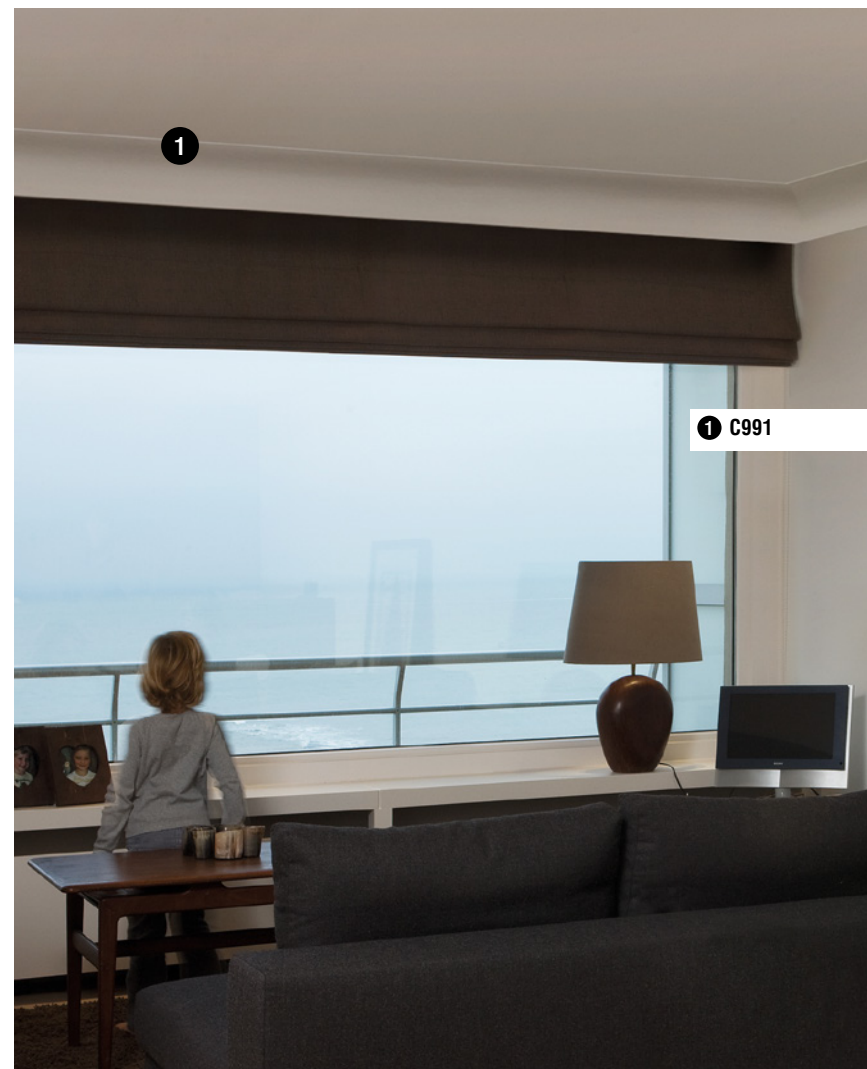
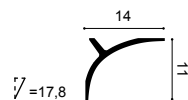

p. 70

Ulf Moritz Collection



G71 SCALA

ULF MORITZ

42,2 x 35 x 1,5 cm
Purotouch[®]

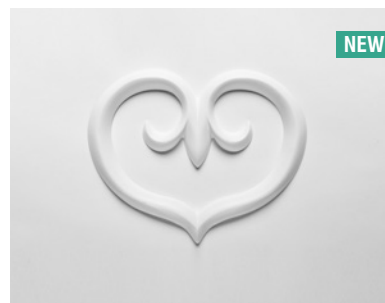
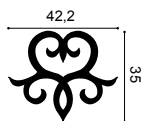

NEW

G75 SCALA

ULF MORITZ

27 x 21 x 1,4 cm
Purotouch[®]

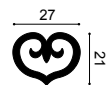

NEW

G76 SCALA

ULF MORITZ

8 x 17,8 x 1,5 cm
Purotouch[®]

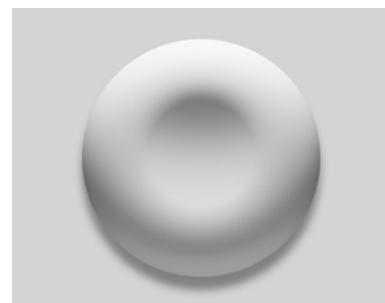

R70 FOCUS

ULF MORITZ

Ø 60 x 7,7 cm
Purotouch[®]

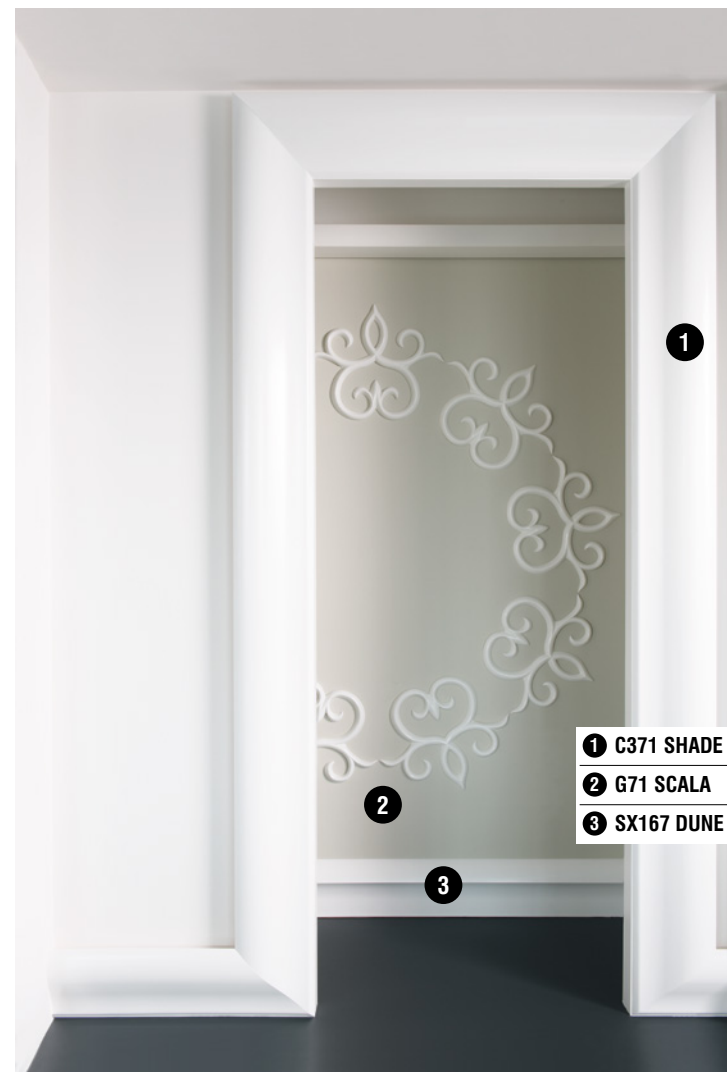
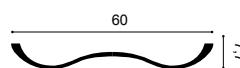

- 1 C371 SHADE** p. 66
- 2 G71 SCALA** p. 71
- 3 SX167 DUNE** p. 67

Ulf Moritz Collection



G70 FOLIO

ULF MORITZ

20 x 9 x 2,7 cm
Duropolymer[®]

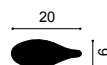

G72 SMILE

ULF MORITZ

42,5 x 6,8 x 1 cm
Duropolymer[®]

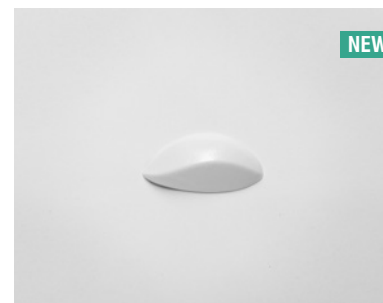
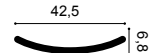

G78 LILY

ULF MORITZ

8,8 x 4,4 x 1,9 cm
Duropolymer[®]



G77 LILY

ULF MORITZ

19,4 x 8,8 x 1,8 cm
Duropolymer[®]



G73L CURL MINI

ULF MORITZ

20,1 x 18,1 x 1 cm
Purotouch[®]

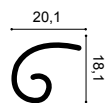

G73R CURL MINI

ULF MORITZ

20,1 x 18,1 x 1 cm
Purotouch[®]

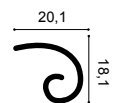

G74L CURL MAXI

ULF MORITZ

25,4 x 24,4 x 1,1 cm
Purotouch[®]

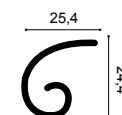

G74R CURL MAXI

ULF MORITZ

25,4 x 24,4 x 1,1 cm
Purotouch[®]

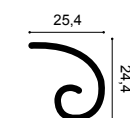



- | | | |
|----|---------------|-------|
| 1 | G77 LILY | p. 72 |
| 2 | P3071 GOLF | p. 67 |
| 3 | C372 FLUXUS | p. 66 |
| 4 | C373 ANTONIO | p. 68 |
| 5 | C374 ANTONIO | p. 68 |
| 6 | G74 CURL MAXI | p. 72 |
| 7 | G72 SMILE | p. 72 |
| 8 | G73 CURL MINI | p. 72 |
| 9 | SX167 DUNE | p. 67 |
| 10 | C371 SHADE | p. 66 |

Ulf Moritz Collection

PARETE / PERETE / WALL / STĚNA / PAREDE

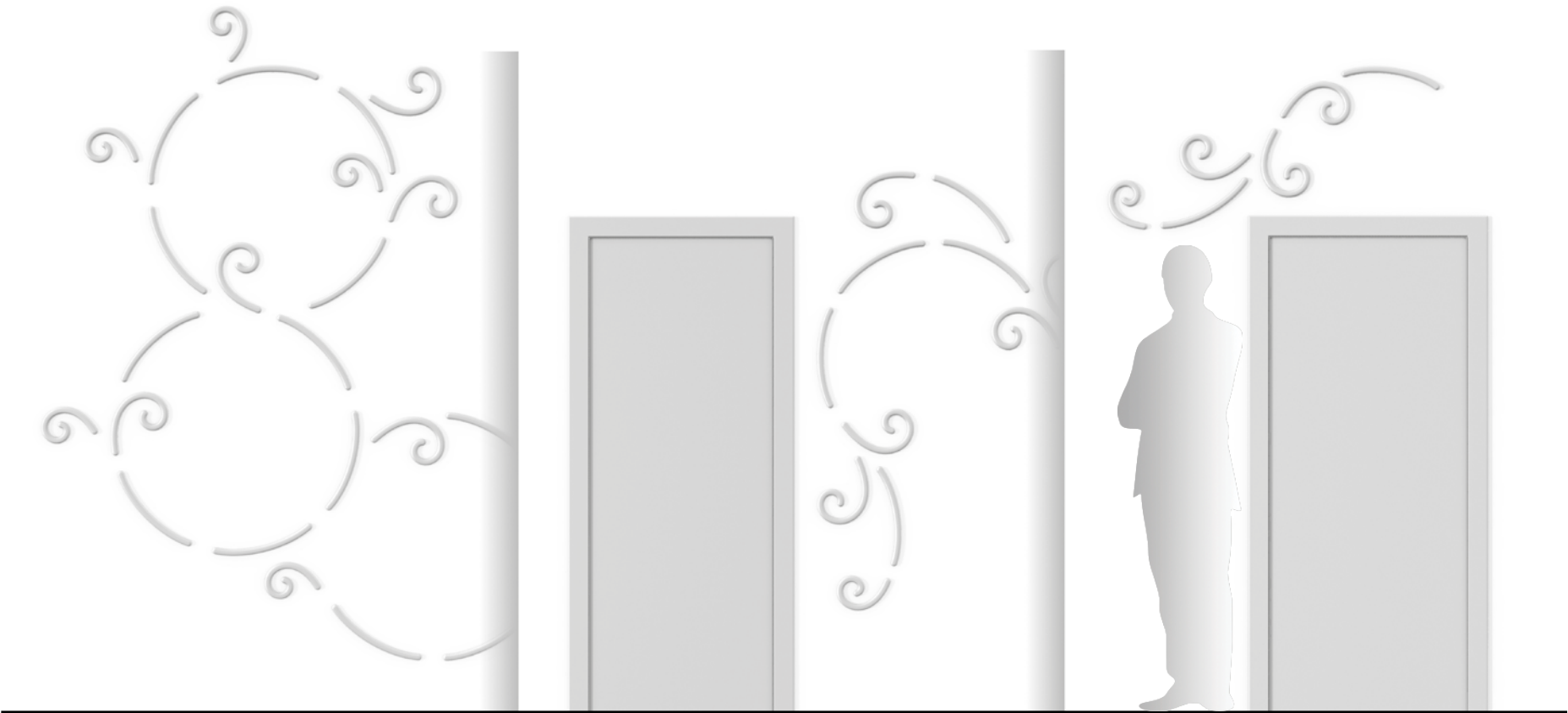

Ulf Moritz Collection

PARETE / PERETE / WALL / STĚNA / PAREDE

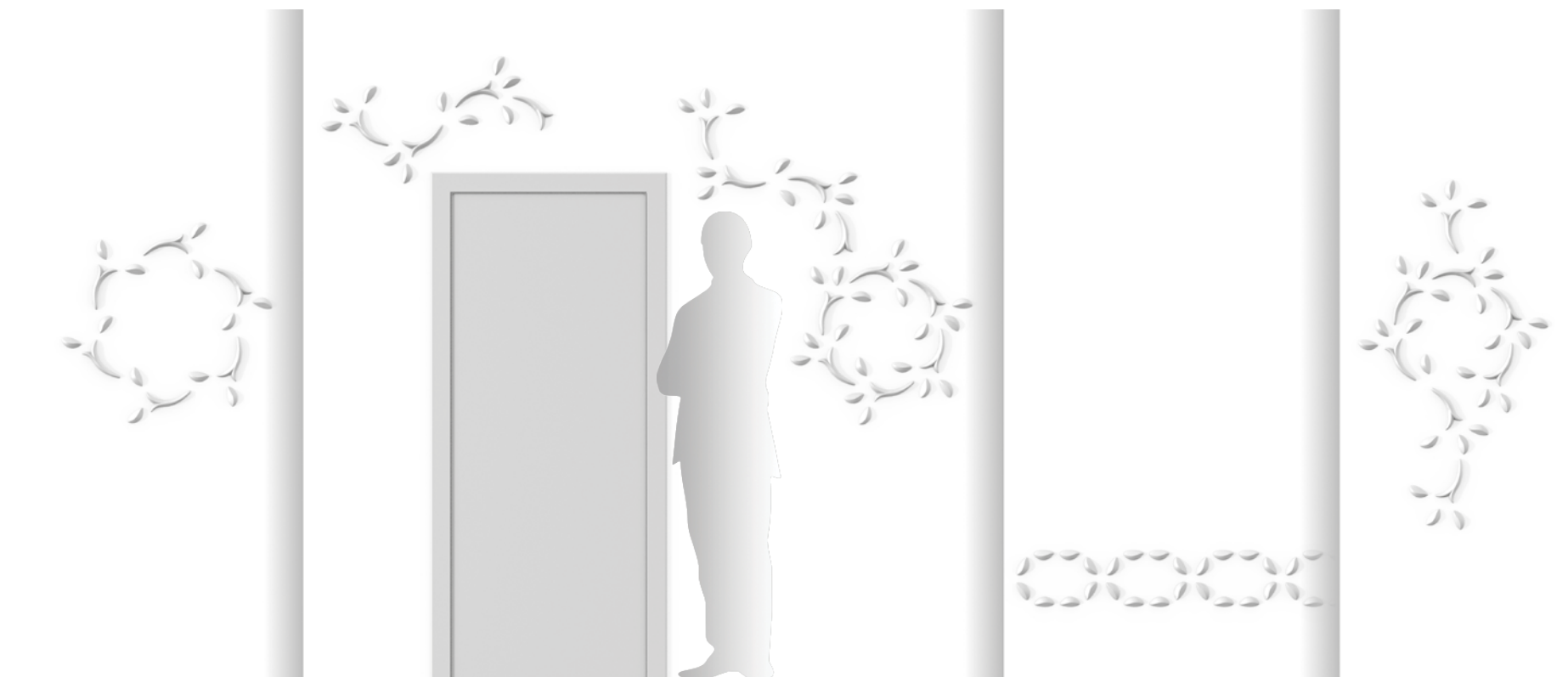

Ulf Moritz Collection

PARETE / PERETE / WALL / STĚNA / PAREDE

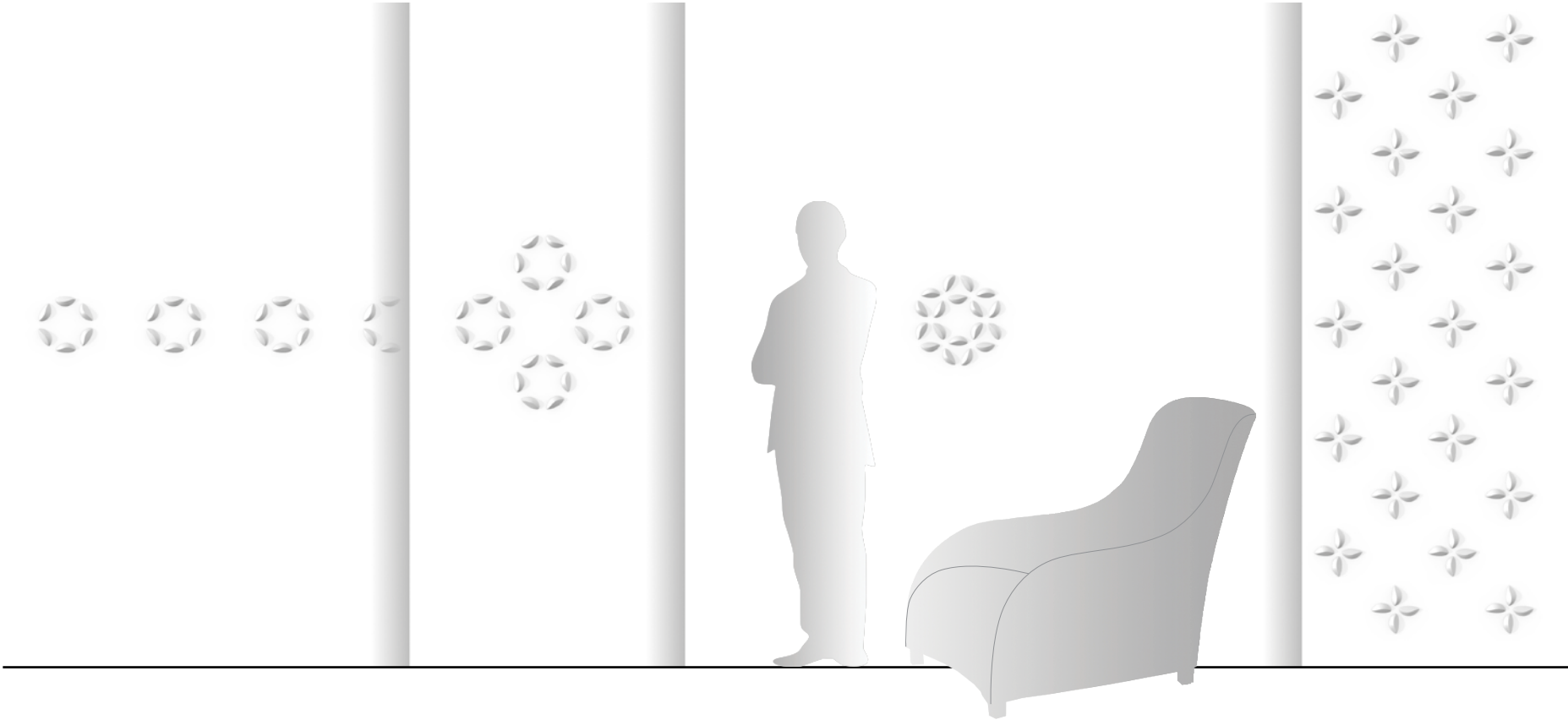

Ulf Moritz Collection

PARETE / PERETE / WALL / STĚNA / PAREDE

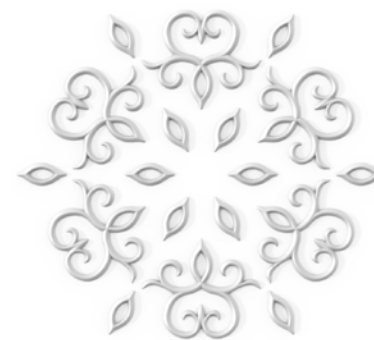
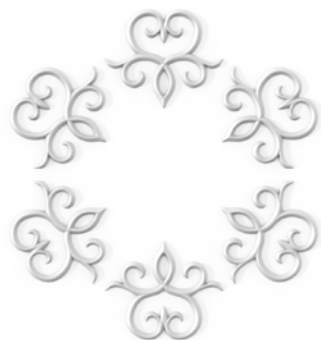

Ulf Moritz Collection

SOFFITTO / PLAFON / CEILING / STROP / TETO

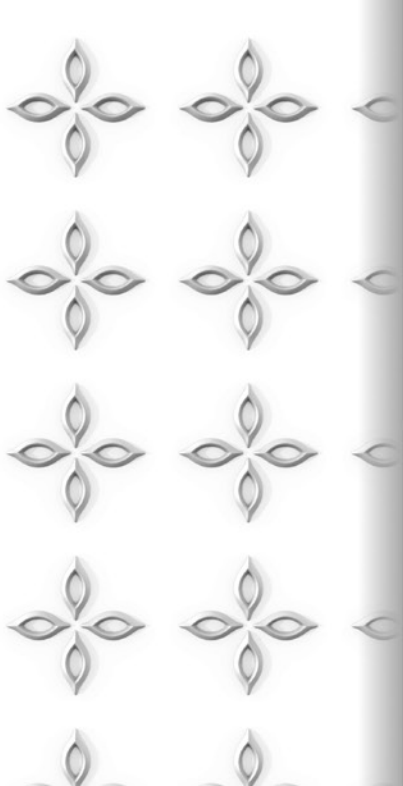
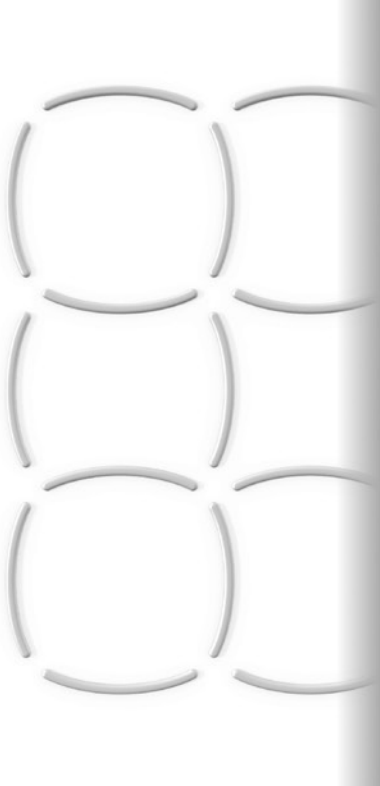

Ulf Moritz Collection

SOFFITTO / PLAFON / CEILING / STROP / TETO

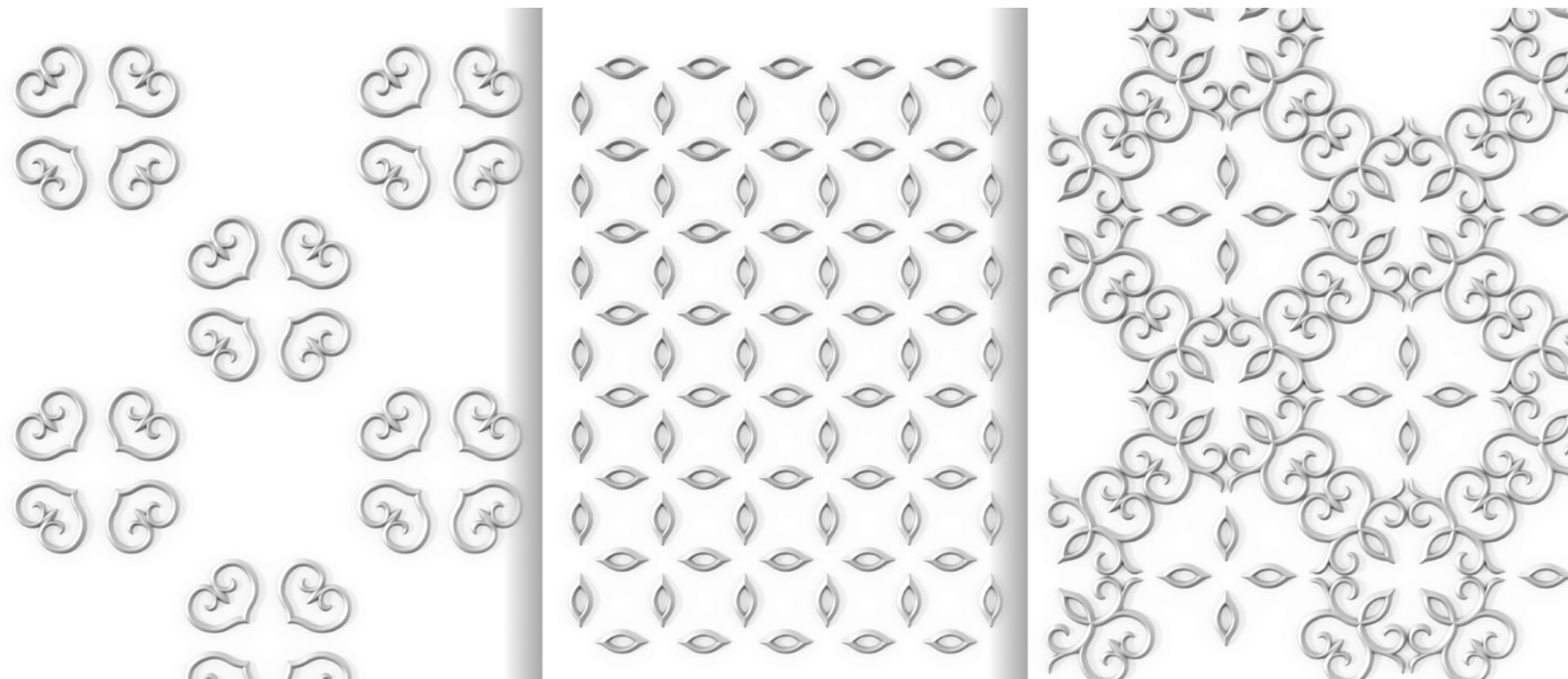



it

Una cornice aggiunge un effetto visivamente interessante nell'unione tra parete e soffitto. Qualunque sia il vostro budget, vi proponiamo una soluzione di qualità: dallo stile minimalista a quello barocco, dall'elemento decorativo a quello prettamente funzionale. Tutti i profili sono facili da installare e molti sono disponibili anche nella versione flessibile.

ro

O cornisa creeaza o tranzitie vizuala atractiva de la perete la tavan. De la elegant la baroque, de la decorativ la functional - oferim o solutie de calitate pentru fiecare buget. Profilele sunt usor de instalat, si o gama larga exista si in varianta flexibila.

en

A cornice creates a visually attractive transition from wall to ceiling. From sleek to baroque, from decorative to functional – we offer a quality solution for every budget. The profiles are easy to install, and a large number of designs are available in flexible versions.

cz

Stropní lišta vytváří vizuálně atraktivní přechod mezi stěnou a stropem. Od uhlazených po barokní, od dekorativních po funkční – nabízíme kvalitní řešení pro každý rozpočet. Profily se snadno instalují a značný počet designů je k dispozici i ve flexibilních verzích.

pt

Uma sanca cria um efeito visual interessante e atraente na transição entre a parede e o teto. Seja qual for o seu orçamento, oferecemos uma solução de qualidade. Do estilo minimalista ao barroco, do decorativo ao funcional. Perfis fáceis de instalar e muitos modelos estão disponíveis em versões flexíveis.

Cornici Soffitto

Cornise

Cornice Mouldings

Stropní lišty

Sancas





C250 | C250F

LUXXUS

200 x 1,6 x 1,6 cm
Purotouch[®]

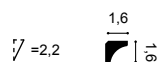

C360

LUXXUS

200 x 2,1 x 6 cm
Purotouch[®]
Designed by
Jacques Vergracht

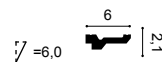

C230 | C230F

LUXXUS

200 x 2,9 x 2,9 cm
Purotouch[®]

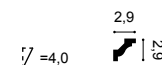

C356

LUXXUS

200 x 2 x 10 cm
Purotouch[®]
Designed by
Jacques Vergracht

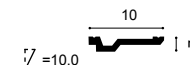

C353

LUXXUS

200 x 3 x 16,5 cm
Purotouch[®]
Designed by
Jacques Vergracht

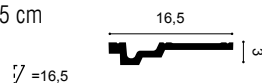

C355

LUXXUS

200 x 3,5 x 11,1 cm
Purotouch[®]
Designed by
Jacques Vergracht

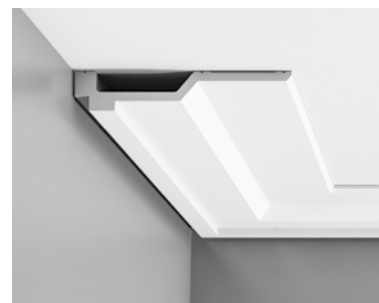
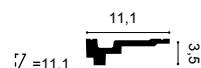

C354

LUXXUS

200 x 4 x 21,5 cm
Purotouch[®]
Designed by
Jacques Vergracht

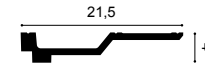

C260 | C260F

LUXXUS

200 x 4,1 x 4,8 cm
Purotouch[®]

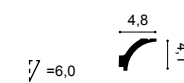

Cornici Soffitto / Cornise /
Cornice Mouldings / Stropní lišty / Sancas



C305 LUXXUS

200 x 4,7 x 15,5 cm
Purotouch[®]

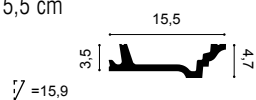

C305 + C213 LUXXUS

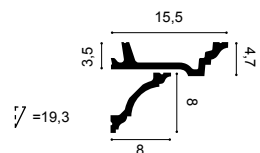

C305 + C211 LUXXUS

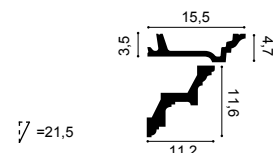

C215 | C215F LUXXUS

200 x 4,7 x 4,7 cm
Purotouch[®]

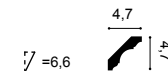

C322 | C322F LUXXUS

200 x 5 x 4,2 cm
Purotouch[®]

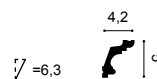

C602 | C602F LUXXUS

200 x 5,3 x 5 cm
Purotouch[®]

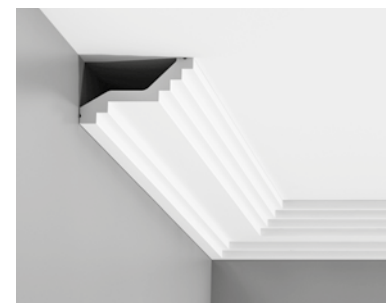
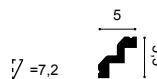

C400 LUXXUS

200 x 6 x 10 cm
Purotouch[®]

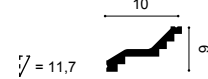

C331 | C331F LUXXUS

200 x 6,4 x 13,5 cm
Purotouch[®]

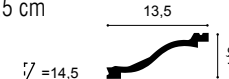



C200 | C200F LUXXUS

200 x 6,5 x 5,7 cm
Purotouch[®]

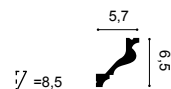

C214 | C214F LUXXUS

200 x 6,6 x 3,1 cm
Purotouch[®]

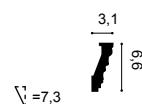

C212 | C212F LUXXUS

200 x 7,3 x 4,5 cm
Purotouch[®]

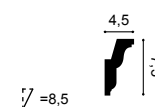

C220 | C220F LUXXUS

200 x 7,6 x 11,6 cm
Purotouch[®]

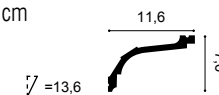

C213 | C213F LUXXUS

200 x 8 x 8 cm
Purotouch[®]

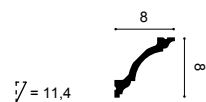

C240 | C240F LUXXUS

200 x 8 x 8 cm
Purotouch[®]

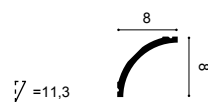

C341 | C341F HERITAGE M LUXXUS

200 x 8,8 x 12,2 cm
Purotouch[®]

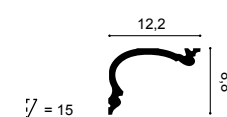

Cornici Soffitto / Cornise /
Cornice Mouldings / Stropní lišty / Sancas



C321 | C321F

LUXXUS

200 x 9,9 x 5 cm
Purotouch[®]

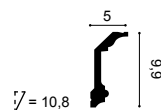

C902 | C902F

LUXXUS

200 x 10,3 x 10,3 cm
Purotouch[®]

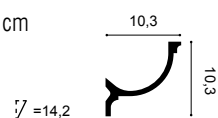

C217 | C217F

LUXXUS

200 x 10,3 x 15,6 cm
Purotouch[®]

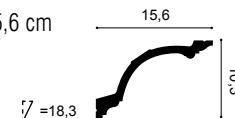

C402 | C402F

LUXXUS

200 x 10,7 x 9,4 cm
Purotouch[®]

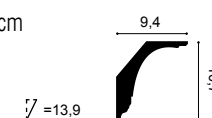

C332

LUXXUS

200 x 11,4 x 23 cm
Purotouch[®]

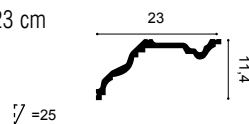

C201 | C201F

LUXXUS

200 x 11,6 x 4,8 cm
Purotouch[®]

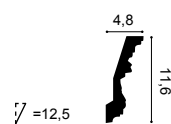

C211 | C211F

LUXXUS

200 x 11,6 x 11,2 cm
Purotouch[®]

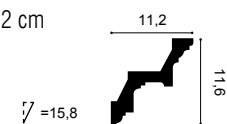

C216 | C216F

LUXXUS

200 x 11,6 x 13,3 cm
Purotouch[®]

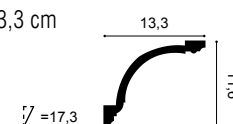



C304 | C304F

LUXXUS

200 x 12,2 x 7,2 cm
Purotouch[®]

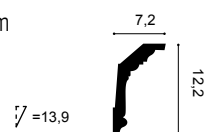

C333 | C333F

LUXXUS

200 x 12,2 x 11,1 cm
Purotouch[®]

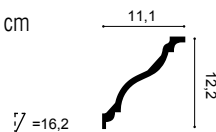

C302 | C302F

LUXXUS

200 x 12,8 x 8,5 cm
Purotouch[®]

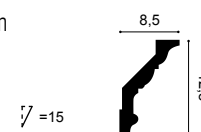

C340

LUXXUS

200 x 13,5 x 25,6 cm
Purotouch[®]

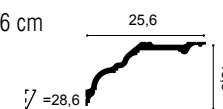

C991 CURTAIN PROFILE

200 x 11 x 14 cm
Purotouch[®]
Designed by
Ulf Moritz

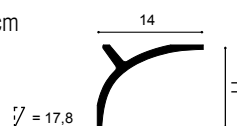

C991



C991 + P9900

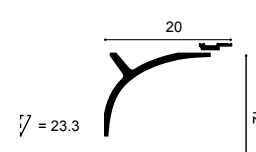

C991 + 2x P9900

ULF MORITZ

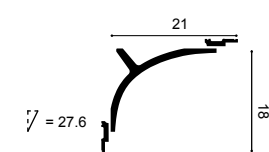



NEW

C342 HERITAGE L

LUXXUS

200 x 14 x 19 cm
Purotouch[®]

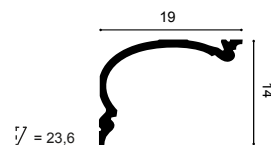

NEW

C339 | C339F

LUXXUS

200 x 14,1 x 6,4 cm
Purotouch[®]

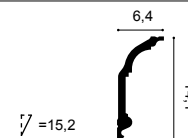

C303 | C303F

LUXXUS

200 x 14,4 x 6,5 cm
Purotouch[®]

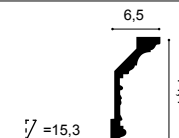

NEW

C991

200 x 14 x 11 cm
Purotouch[®]
Designed by
Ulfi Moritz

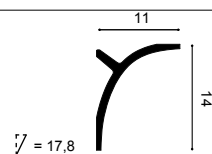

NEW

C991 + P9900

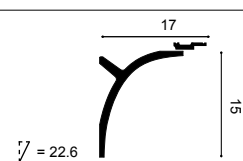

NEW

C991 + 2x P9900

ULF MORITZ

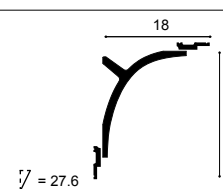

C218 | C218F

LUXXUS

200 x 15 x 12 cm
Purotouch[®]

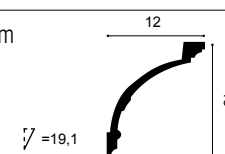



C334 | C334F LUXXUS

200 x 15 x 19,6 cm
Purotouch[®]

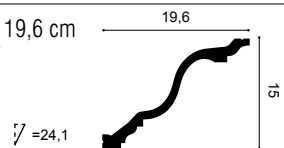

C901 | C901F LUXXUS

200 x 14,8 x 12,4 cm
Purotouch[®]



C217 | C217F LUXXUS

200 x 15,6 x 10,3 cm
Purotouch[®]

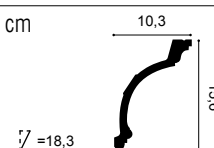

C300 LUXXUS

200 x 16,5 x 13 cm
Purotouch[®]

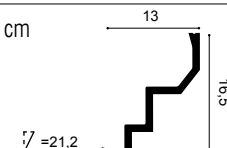

C990 INFINITY

200 x 15,9 x 21,6 cm
Purotouch[®]
Designed by
Xavier Donck



C990 + P9900

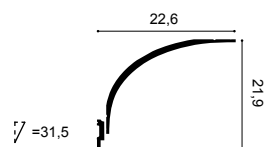

C990 + 2x P9900

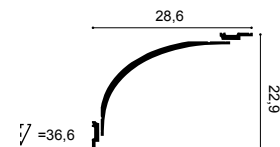

C990 + P9901 LUXXUS

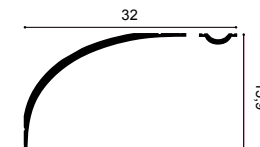

Cornici Soffitto / Cornise /
Cornice Mouldings / Stropní lišty / Sancas



C900 LUXXUS

200 x 17,1 x 14,6 cm
Purotouch[®]

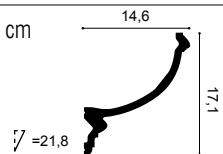

C422 LUXXUS

200 x 16,4 x 19,4 cm
Purotouch[®]

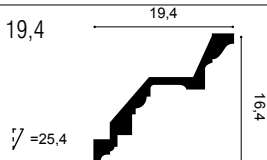

C301 | C301F LUXXUS

200 x 17 x 14,4 cm
Purotouch[®]

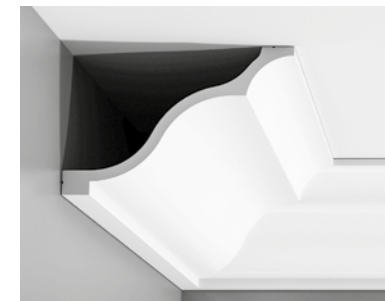
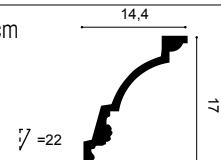

C337 LUXXUS

200 x 17,2 x 25,6 cm
Purotouch[®]

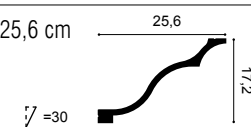

C219 LUXXUS

200 x 17,6 x 13 cm
Purotouch[®]

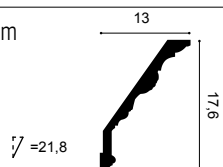

C338 LUXXUS

200 x 18,4 x 18,4 cm
Purotouch[®]



C338A BA'ROCK LUXXUS

200 x 18,4 x 18,4 cm
Purotouch[®]

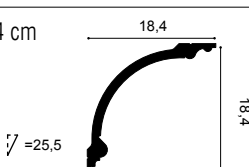

C338B BA'ROCK LUXXUS

200 x 18,4 x 18,4 cm
Purotouch[®]





C343 HERITAGE XL LUXXUS

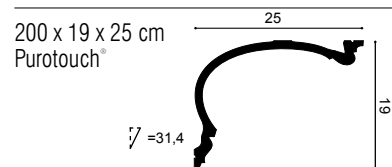

C990 INFINITY

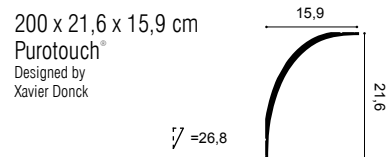

C307 LUXXUS

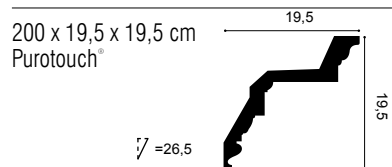

C990 + P9900

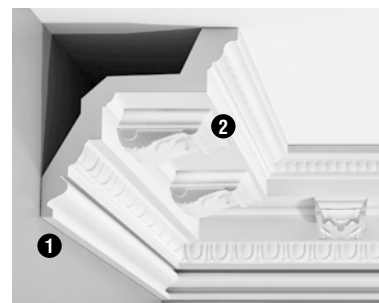
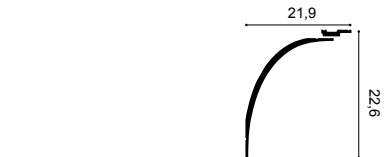

1 C307 + C307A 2 LUXXUS

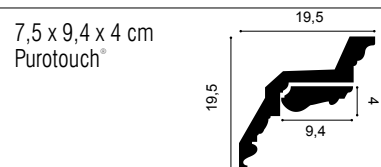

C990 + 2x P9900

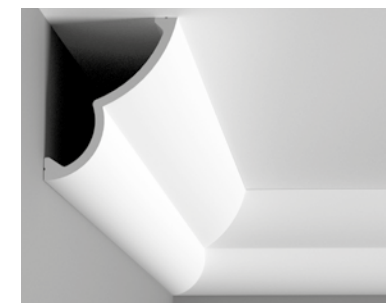
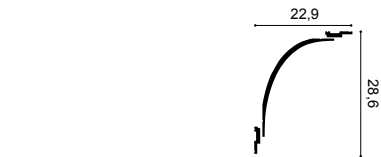

C370 CLOUD ULF MORITZ

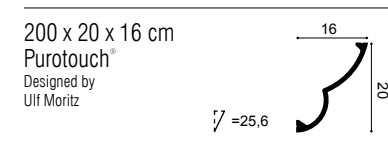

C990 + P9901 LUXXUS

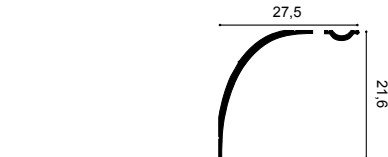

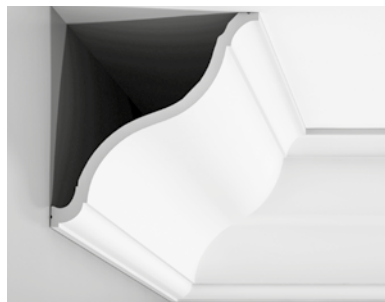

C335 LUXXUS

200 x 20,2 x 22,2 cm
Purotouch[®]
Designed by
Xavier Donck

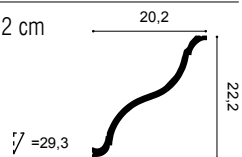

C340 LUXXUS

200 x 25,6 x 13,5 cm
Purotouch[®]

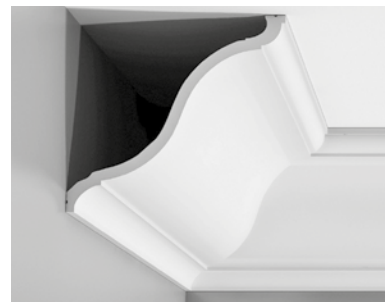
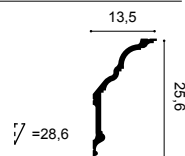

C335 LUXXUS

200 x 22,2 x 20 cm
Purotouch[®]
Designed by
Xavier Donck

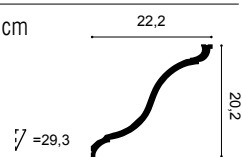

C336 LUXXUS

200 x 27,1 x 26,6 cm
Purotouch[®]

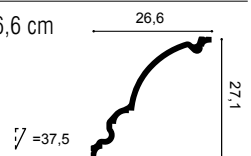

C332 LUXXUS

200 x 23 x 11,4 cm
Purotouch[®]

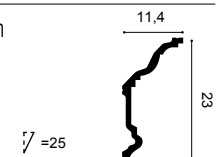

C344 HERITAGE XXL LUXXUS

200 x 27,3 x 35 cm
Purotouch[®]

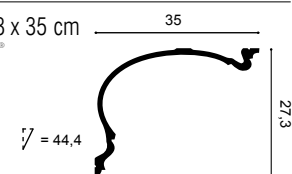

C308 | C308F LUXXUS

200 x 24,8 x 6,3 cm
Purotouch[®]

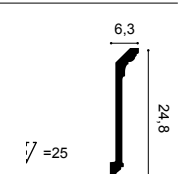

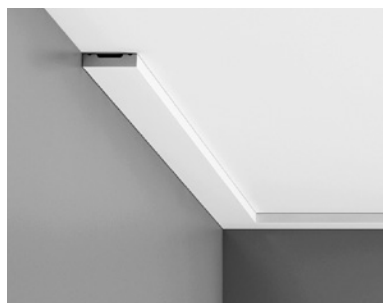

DX162-2300

AXXENT

230 x 1 x 4 cm
Duropolymer[®]



DX159-2300

AXXENT

230 x 1,2 x 6 cm
Duropolymer[®]



CX160

AXXENT

200 x 1,3 x 3,9 cm
Duropolymer[®]



DX157-2300 | DX157F

AXXENT

230 x 6,6 x 1,3 cm (DX157-2300)
200 x 6,6 x 1,3 cm (DX157F)
Duropolymer[®]



CX161

AXXENT

200 x 1,3 x 6,9 cm
Duropolymer[®]



DX163-2300

AXXENT

230 x 1,3 x 10,2 cm
Duropolymer[®]

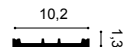

DX168-2300

AXXENT

230 x 1,4 x 15,1 cm
Duropolymer[®]

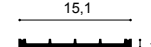

CX132 | CX132F

AXXENT

200 x 2 x 2 cm
Duropolymer[®]

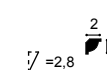

Cornici Soffitto / Cornise /
Cornice Mouldings / Stropní lišty / Sancas



CX133

AXXENT

200 x 2 x 2 cm
Duropolymer[®]

$\nabla = 2,7$  2 | ∞



CX111

AXXENT

200 x 2,6 x 1,5 cm
Duropolymer[®]

$\nabla = 2,8$  1,5 | 2,6

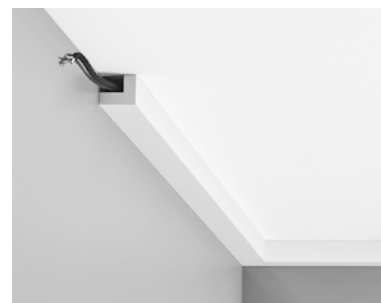

PX164

AXXENT

200 x 2,4 x 3 cm
Duropolymer[®]

$\nabla = 3,9$  3 | 2,4



CX115

AXXENT

200 x 3 x 2,9 cm
Duropolymer[®]

$\nabla = 3,9$  2,9 | ∞



CX154

AXXENT

200 x 3 x 3 cm
Duropolymer[®]

$\nabla = 4,1$  3 | ∞



CX148 | CX148F

AXXENT

200 x 4,3 x 2,9 cm
Duropolymer[®]

$\nabla = 5,1$  2,9 | 4,3



CX149

AXXENT

200 x 4,3 x 2,9 cm
Duropolymer[®]

$\nabla = 5,1$  2,9 | 4,3



CX150

AXXENT

200 x 4,3 x 2,9 cm
Duropolymer[®]

$\nabla = 5,1$  2,9 | 4,3

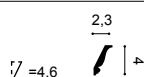

CX151 AXSENT
200 x 4,0 x 2,3 cm
Duropolymer[®]
∠ = 4,6 

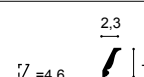

CX152 AXSENT
200 x 4,0 x 2,3 cm
Duropolymer[®]
∠ = 4,6 

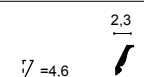

CX153 AXSENT
200 x 4,0 x 2,3 cm
Duropolymer[®]
∠ = 4,6 

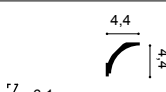

CX109 | CX109F AXSENT
200 x 4,4 x 4,4 cm
Duropolymer[®]
∠ = 6,1 

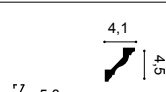

CX110 | CX110F AXSENT
200 x 4,5 x 4,1 cm
Duropolymer[®]
∠ = 5,8 

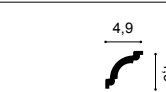

CX124 | CX124F AXSENT
200 x 4,9 x 4,9 cm
Duropolymer[®]
∠ = 6,8 



CX112 AXSENT
200 x 5,4 x 3,8 cm
Duropolymer[®]
∠ = 6,6 

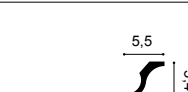

CX108 AXSENT
200 x 5,4 x 5,5 cm
Duropolymer[®]
∠ = 7,6 

Cornici Soffitto / Cornise /
Cornice Mouldings / Stropní lišty / Sancas



CX141

AXXENT

200 x 5,9 x 3,1 cm
Duropolymer[®]

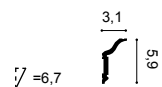

CX142

AXXENT

200 x 5,9 x 3,1 cm
Duropolymer[®]

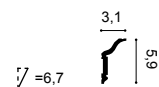

CX143

AXXENT

200 x 5,9 x 3,1 cm
Duropolymer[®]

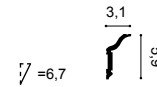

CX100 | CX100F

AXXENT

200 x 6,9 x 7,1 cm
Duropolymer[®]

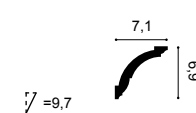

CX101

AXXENT

200 x 6,9 x 7,1 cm
Duropolymer[®]

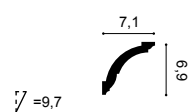

CX136

AXXENT

200 x 6,9 x 7,1 cm
Duropolymer[®]

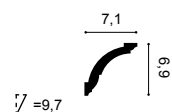

CX123

AXXENT

200 x 8 x 8 cm
Duropolymer[®]

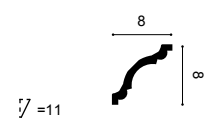

CX126

AXXENT

200 x 8,7 x 8,7 cm
Duropolymer[®]

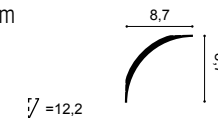



CX127 | CX127F

AXXENT

200 x 9,4 x 9,4 cm
Duropolymer[®]

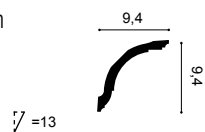

CX128

AXXENT

200 x 9,4 x 9,4 cm
Duropolymer[®]

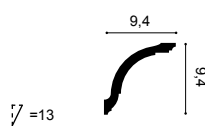

CX106

AXXENT

200 x 11,8 x 11,7 cm
Duropolymer[®]

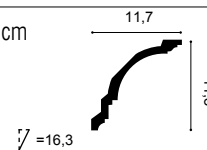

CX129

AXXENT

200 x 9,4 x 9,4 cm
Duropolymer[®]

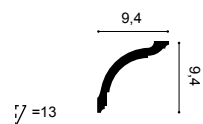

CX107

AXXENT

200 x 11,8 x 11,7 cm
Duropolymer[®]

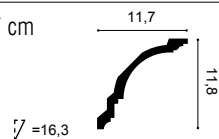

Cornici Soffitto / Cornise /
Cornice Mouldings / Stropní lišty / Sancas



CB500 BASIXX
200 x 2,5 x 1,8 cm
Durofoam[®]
1,8
2,5
∠ = 3



CB530 BASIXX
200 x 2,7 x 1,5 cm
Durofoam[®]
1,5
2,7
∠ = 3,2



CB520 BASIXX
200 x 3,5 x 3,5 cm
Durofoam[®]
3,5
3,5
∠ = 5



CB510 BASIXX
200 x 4 x 4 cm
Durofoam[®]
4
4
∠ = 5,6



CB501 BASIXX
200 x 4,1 x 3,5 cm
Durofoam[®]
3,5
4,1
∠ = 5,3



CB531 BASIXX
200 x 4,2 x 2,6 cm
Durofoam[®]
2,6
4,2
∠ = 5,2



CB521 BASIXX
200 x 5 x 5 cm
Durofoam[®]
5
5
∠ = 7,1



CB523 BASIXX
200 x 5,9 x 4,4 cm
Durofoam[®]
4,4
5,9
∠ = 7,2



CB502 BASIXX
200 x 5,9 x 4,9 cm
Durofoam[®]
4,9
5,9
∠ = 7,8



CB511 BASIXX
200 x 6,7 x 6,7 cm
Durofoam[®]
6,7
6,7
∠ = 9,8



CB522 BASIXX
200 x 6,7 x 6,7 cm
Durofoam[®]
6,7
6,7
∠ = 9,7

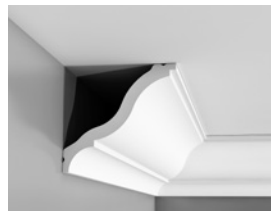

CB503 BASIXX
200 x 8,2 x 9,2 cm
Durofoam[®]
9,2
8,2
∠ = 12,3



CB512 BASIXX
200 x 10 x 10 cm
Durofoam[®]
10
10
∠ = 13,8



PB513 BASIXX
200 x 3,4 x 1,5 cm
Durofoam[®]
3,4
1,5
∠ = 1

ORAC FLEX (REF + F)

Cornici Soffitto / Cornise / Cornice Mouldings / Stropní lišty / Sancas

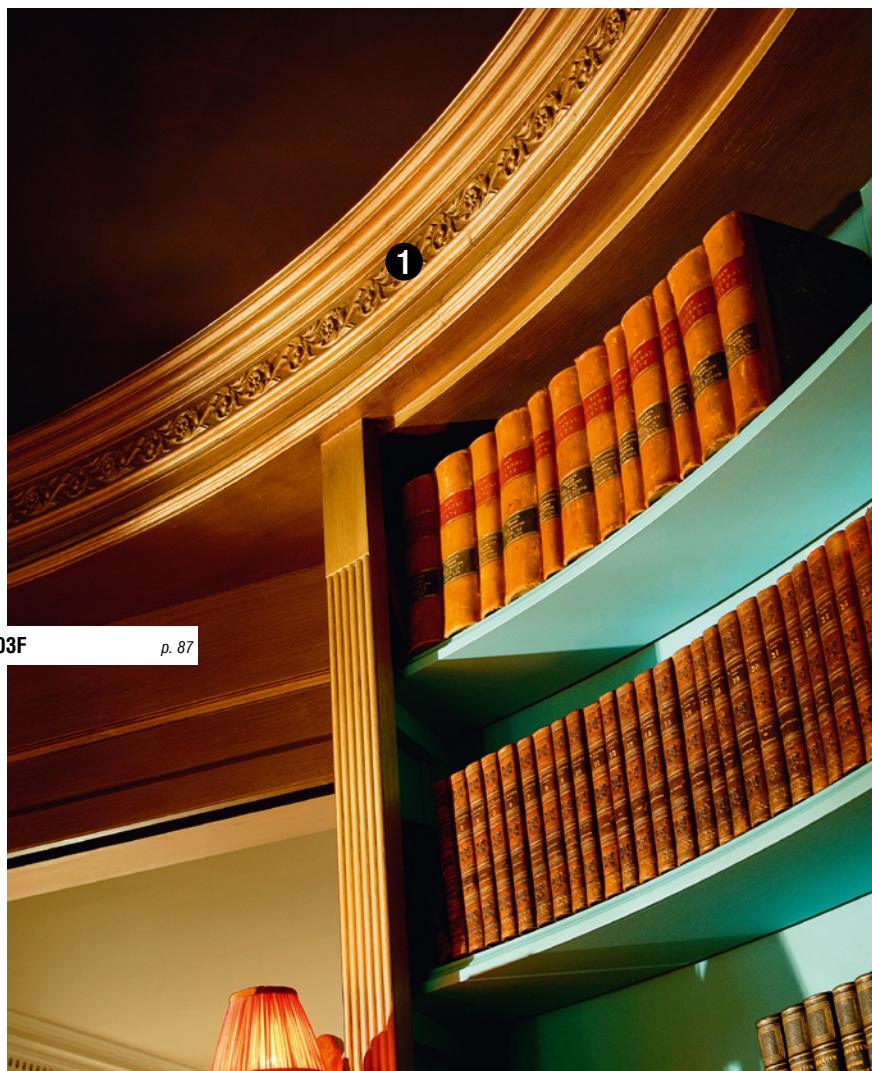

1 C303F p. 87

LUXXUS	cm		cm
	R min	C339F	380
C200F	160	C341F	400
C201F	200	C373F	100
C211F	250	C374F	130
C212F	120	C402F	300
C213F	280	C602F	100
C214F	140	C901F	600
C215F	160	C902F	600
C216F	340		
C217F	380		
C218F	360		
C220F	400		
C230F	150		
C240F	270		
C250F	70		
C260F	130		
C301F	320		
C302F	250		
C303F	180		
C304F	250		
C308F	120		
C321F	140		
C322F	160		
C331F	420		
C333F	300		
C334F	380		

AXXENT	cm
	R min
CX100F	200
CX109F	160
CX110F	180
CX124F	160
CX127F	240
CX132F	70
CX148F	180

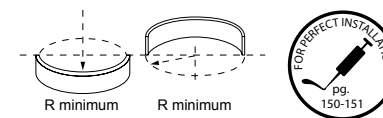



- | | | |
|---|--------------|-------|
| ❶ | C307 + C307A | p. 90 |
| ❷ | C354 | p. 82 |



it

Portare nuova vita ad un semplice muro è ciò che chiamiamo "wallscaping". L' ampia gamma di cornici permette di creare in un batter d'occhio un lambris o un riquadro sulla parete o sul soffitto. Tutti i profili sono facili da posare e molti sono disponibili anche nella versione flessibile per pareti e soffitti curvi.

ro

Pentru ca peretii banali sa revina la viata utilizam metoda "wallscaping" folosind gama noastra larga de produse. Creati panouri si ancadramente atractive pe pereti si tavane intr-o clipita. Toate decoratiunile sunt usor de instalat, si multe sunt disponibile in forma flexibila pentru a putea fi folosite pe pereti si tavane curbe.

en

Make flat walls come to life using "wallscaping" with our extensive panel mould range. Create attractive panelling or frames on walls and ceilings in a jiffy. All designs are easy to install, and many are available in a flexible format for use on curved walls and ceilings.

cz

Oživte ploché stěny metodou „wallscaping“ pomocí naší početné řady lemovacích lišt. Umožní vám bleskově vytvářet na stěnách a stropích atraktivní obklady nebo rámečky. Všechny designy se snadno instalují a mnohé jsou k dispozici ve flexibilní verzi, takže se dají použít na zakřivených stěnách a stropích.

pt

Dar vida a uma parede lisa, chamamos a isso de "wallscaping". Utilizando a nossa extensa gama de perfis poderá criar painéis ou quadros atraentes em paredes e tectos num instante. Além de que são extremamente fáceis de instalar e muitos estão disponíveis em versão flexível para utilização em paredes e tetos.

Cornici Parete
Brauri
Panel Mouldings
Lemovací lišty
Perfis





P9050 | P9050F

LUXXUS

200 x 2,5 x 1,3 cm
Purotouch[®]



P5021 | P5021F

LUXXUS

200 x 3,1 x 0,9 cm
Purotouch[®]



P8030 | P8030F

LUXXUS

200 x 4,1 x 1,7 cm
Purotouch[®]



P2020 | P2020F

LUXXUS

200 x 4,4 x 2,6 cm
Purotouch[®]



P1020 | P1020F

LUXXUS

200 x 4,9 x 2,4 cm
Purotouch[®]



P9040 | P9040F

LUXXUS

200 x 5 x 2,5 cm
Purotouch[®]



P4020 | P4020F

LUXXUS

200 x 5 x 2,9 cm
Purotouch[®]

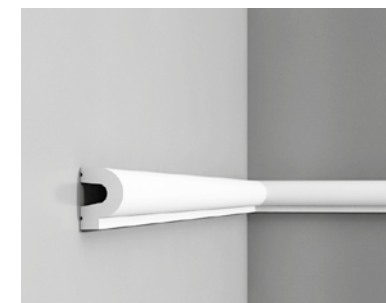

P8060 | P8060F

LUXXUS

200 x 5 x 3,5 cm
Purotouch[®]





P8020 | P8020F

LUXXUS

200 x 6 x 2,6 cm
Purotouch[®]



P3020 | P3020F

LUXXUS

200 x 6,1 x 3,2 cm
Purotouch[®]



P6020 | P6020F

LUXXUS

200 x 6,4 x 2,8 cm
Purotouch[®]



P9901 | P9901F

LUXXUS

200 x 7 x 1,4 cm
Purotouch[®]



P7070 | P7070F

LUXXUS

200 x 7,4 x 2,2 cm
Purotouch[®]



P7040 | P7040F

LUXXUS

200 x 7,9 x 2,6 cm
Purotouch[®]



P9900 | P9900F

LUXXUS

200 x 8 x 1 cm
Purotouch[®]



P5051

LUXXUS

200 x 8,4 x 1,5 cm
Purotouch[®]
Designed by
Jacques Vergracht





P7030 | P7030F

LUXXUS

200 x 8,5 x 1,7 cm
Purotouch[®]



P5020 | P5020F

LUXXUS

200 x 9,1 x 1,3 cm
Purotouch[®]



P9010 | P9010F

LUXXUS

200 x 9,1 x 3 cm
Purotouch[®]



DX119-2300

LUXXUS

230 x 9,2 x 2,2 cm
Duropolymer[®]



DX121-2300

LUXXUS

230 x 9,4 x 2,3 cm
Duropolymer[®]

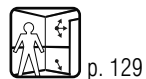

P9020 | P9020F

LUXXUS

200 x 9,6 x 2,1 cm
Purotouch[®]



P8040 | P8040F

LUXXUS

200 x 10,1 x 2,2 cm
Purotouch[®]

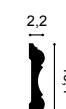

P7010 | P7010F

LUXXUS

200 x 10,5 x 2 cm
Purotouch[®]

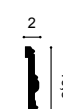



P7020 | P7020F

LUXXUS

200 x 11,1 x 1,9 cm
Purotouch[®]



P5050

LUXXUS

200 x 20 x 1,5 cm
Purotouch[®]
Designed by
Jacques Vergracht



DX170-2300 HERITAGE

LUXXUS

230 x 11,9 x 3,2 cm
Duropolymer[®]



p. 129



P7080

LUXXUS

200 x 21,8 x 2,9 cm
Purotouch[®]



P8050 | P8050F

LUXXUS

200 x 12 x 3 cm
Purotouch[®]

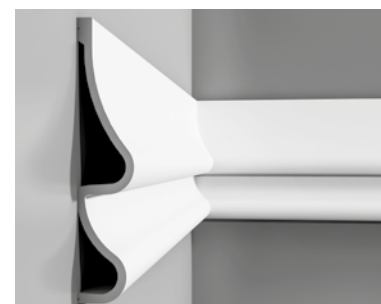

P3071 GOLF

ULF MORITZ

200 x 37,2 x 7,6 cm
Purotouch[®]
Designed by
Ulf Moritz

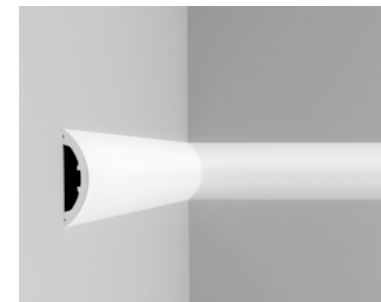

P3070 RADIUS

ULF MORITZ

200 x 12,5 x 3,2 cm
Purotouch[®]
Designed by
Ulf Moritz





PX103 | PX103F

AXXENT

200 x 2,5 x 1,2 cm
Duropolymer[®]

1,2
▶ | 2,5



PX116

AXXENT

200 x 3,1 x 1 cm
Duropolymer[®]

1
▶ | 3,1



PX117

AXXENT

200 x 3,5 x 1,5 cm
Duropolymer[®]

1,5
▶ | 3,5



DX162-2300

AXXENT

230 x 4 x 1 cm
Duropolymer[®]

1
▶ | 4



p. 129



PX120 | PX120F

AXXENT

200 x 4 x 1,9 cm
Duropolymer[®]

1,9
▶ | 4



PX131

AXXENT

200 x 4 x 1,9 cm
Duropolymer[®]

1,9
▶ | 4



PX144 | PX144F

AXXENT

200 x 4,7 x 0,8 cm
Duropolymer[®]

0,8
▶ | 4,7



PX145

AXXENT

200 x 4,7 x 0,8 cm
Duropolymer[®]

0,8
▶ | 4,7



PX146

AXXENT

200 x 4,7 x 0,8 cm
Duropolymer[®]



PX113

AXXENT

200 x 6 x 2,7 cm
Duropolymer[®]



PX114

AXXENT

200 x 6 x 2,7 cm
Duropolymer[®]



DX159-2300

AXXENT

230 x 6 x 1,2 cm
Duropolymer[®]



p. 129



DX157-2300 | DX157F

AXXENT

230 x 6,6 x 1,3 cm (DX157-2300)
200 x 6,6 x 1,3 cm (DX157F)
Duropolymer[®]



p. 129



PX102

AXXENT

200 x 7,9 x 1,6 cm
Duropolymer[®]



DX163-2300

AXXENT

230 x 10,2 x 1,3 cm
Duropolymer[®]



p. 129

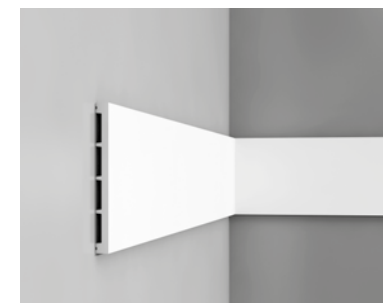

DX168-2300

AXXENT

230 x 15,1 x 1,4 cm
Duropolymer[®]



p. 129



PX164

AXXENT

200 x 2,4 x 3 cm
Duropolymer[®]



PX147

200 x 16,9 x 0,9 cm
Duropolymer[®]

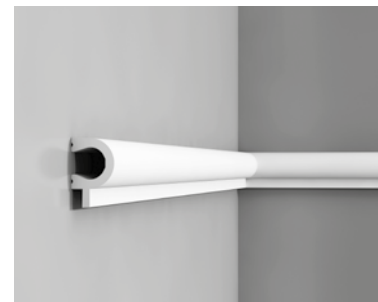
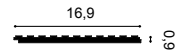

PX169

200 x 5,5 x 3,4 cm
Duropolymer[®]



PX147 + PX169

AXXENT

Duropolymer[®]



CX134

AXXENT

200 x 3 x 3 cm
Duropolymer[®]

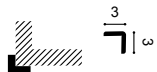

- | | | |
|---|------------|--------|
| 1 | PX164 | p. 108 |
| 2 | DX163-2300 | p. 107 |
| 3 | DX157-2300 | p. 107 |
| 4 | DX163-2300 | p. 107 |
| 5 | DX162-2300 | p. 106 |

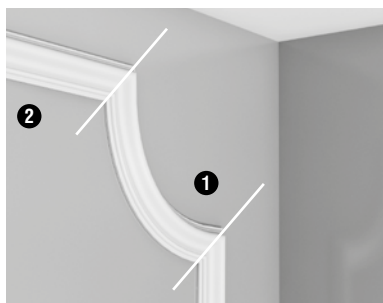

❶ P8030C + P8030 ❷

19 x 8,6 x 1,7 cm
Duropolymer[®]



P8030D

LUXXUS

13,2 x 13,2 x 1,7 cm
Duropolymer[®]



❶ P801C + P8020 ❷

19,8 x 11 x 2,6 cm
Purotouch[®]

LUXXUS



P4020A + P4020

LUXXUS

16,4 x 9,1 x 2,9 cm
Purotouch[®]

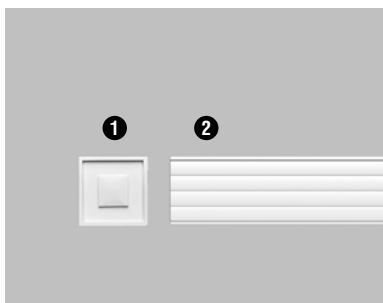

❶ P5020B + P5020 ❷

9 x 9 x 1,3 cm
Purotouch[®]

LUXXUS

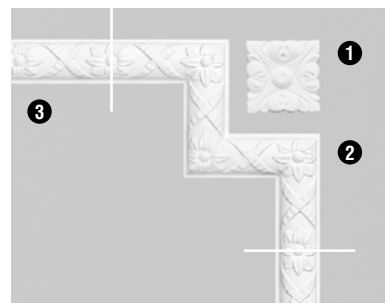
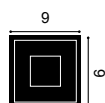

❶ P21

LUXXUS

6,7 x 6,7 x 0,9 cm
Purotouch[®]

❷ P201A + P2020 ❸

LUXXUS

19,5 x 19,5 x 2,6 cm
Purotouch[®]

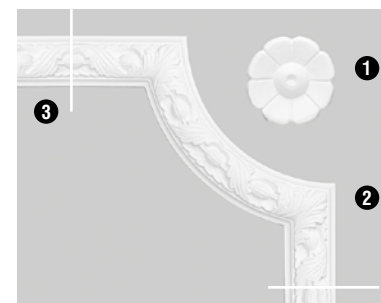

❶ P20

LUXXUS

Ø 6,1 x 0,8 cm
Duropolymer[®]

❷ P101A + P1020 ❸

LUXXUS

24,5 x 24,5 x 2,4 cm
Purotouch[®]

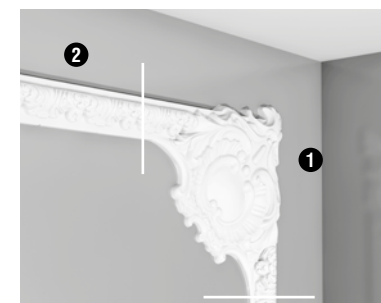

❶ P3020A + P3020 ❷

LUXXUS

42,5 x 42,5 x 4 cm
Purotouch[®]

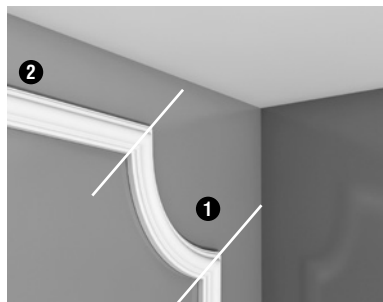

1 PX120A + PX120 2 AXSENT

19 x 8,8 x 2 cm
Duropolymer[®]

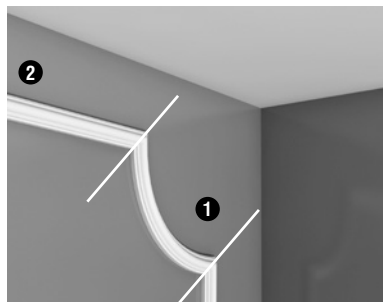

1 PX103A + PX103 2 AXSENT

19 x 3,5 x 1,2 cm
Duropolymer[®]



- | | |
|-----------------|---------------|
| 1 C217 | <i>p. 85</i> |
| 2 P8030D | <i>p. 109</i> |
| 3 P8030 | <i>p. 102</i> |
| 4 P9010 | <i>p. 104</i> |
| 5 SX118 | <i>p. 116</i> |

ORAC FLEX (REF + F)

Cornici Parete / Brauri / Panel Mouldings / Lemovací lišty / Perfis



AXXENT	cm	cm
	R min	R* min
DX157F	35	260
PX103F	20	80
PX120F	30	110
PX144F	20	220

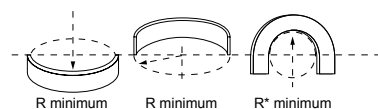

LUXXUS	cm	cm
	R min	R* min
P1020F	30	80
P2020F	30	80
P3020F	50	180
P4020F	40	200
P5020F	30	
P5021F	20	70
P6020F	30	250
P7010F	20	

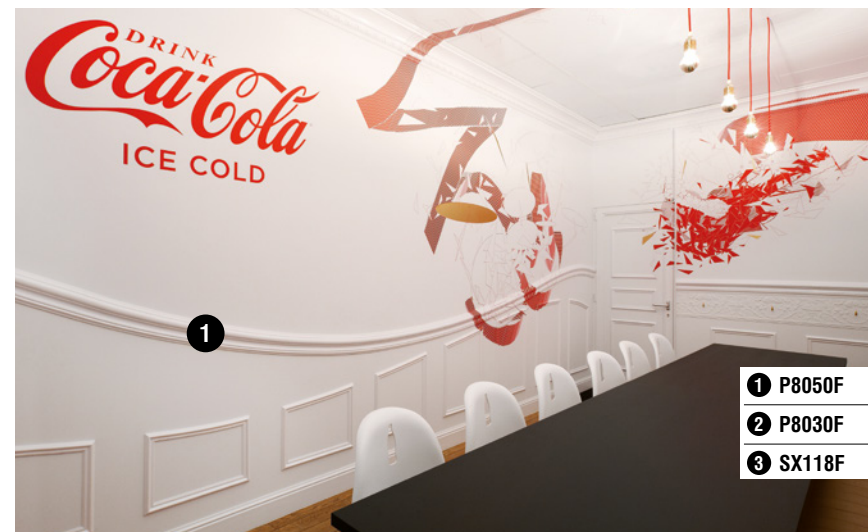

1 P8050F	p. 105
2 P8030F	p. 102
3 SX118F	p. 116

	cm	cm	cm	cm
	R min	R* min	R min	R* min
P7020F	30		P8060F	80 200
P7030F	30	250	P9010F	40 310
P7040F	40	320	P9020F	30
P7070F	30	230	P9040F	30 80
P8020F	40	130	P9050F	20 60
P8030F	20	70	P9900F	20 250
P8040F	30		P9901F	20 180
P8050F	80	200		



it

Tutti i battiscopa sono realizzati in Duropolymer®, una miscela di polimeri resistente agli urti e all'acqua completamente riciclabile. I cavi possono essere facilmente nascosti e, nella versione flessibile, sono la soluzione ideale per pareti curve. I battiscopa sono trattati con un primer per poter essere facilmente verniciati.

ro

Toate plintele sunt realizate din Duropolymer®, un amestec de polimer rezistent la impact și apă, care este 100% reciclabil. Acestea permit ascunderea cablurilor cu ușurință, iar varianta flexibilă permite finisarea elegantă a peretilor curbi. Plintele vin deja cu un strat de grund și pot fi ușor vopsite.

en

All skirting boards are made from Duropolymer®, an impact- and water-resistant polymer mix that is fully recyclable. Cables can be hidden easily, and the flexible versions allow curved walls to be finished elegantly. The skirting boards are pre-primed for easy painting.

cz

Všechny podlahové lišty jsou vyrobeny z materiálu Duropolymer®, což je mechanicky a voděodolná polymerová směs. Tento materiál je plně recyklovatelný. Umožňují snadno skryt kabely a pomocí flexibilních verzí je možné elegantně zakončit zakřivené stěny. Podlahové lišty jsou natřeny základním nátěrem, takže je lze snadno přetírat.

pt

Todos os rodapés são produzidos com Duropolymer®, uma mistura de polímeros de alta densidade, resistentes à água e a impactos, totalmente reciclável. Os cabos podem ser facilmente ocultados e as versões flexíveis permitem, para paredes curvas, um acabamento elegante e distinto. Os rodapés vêm com uma camada de primário, para uma pintura fácil.

Battiscopa

Plinte

Skirting

Podlahové lišty

Rodapés





CX132 | CX132F

AXXENT

200 x 2 x 2 cm
Duropolymer®



CX133

AXXENT

200 x 2 x 2 cm
Duropolymer®



DX162-2300

AXXENT

230 x 4 x 1 cm
Duropolymer®



DX159-2300

AXXENT

230 x 6 x 1,2 cm
Duropolymer®



DX157-2300 | DX157F

AXXENT

230 x 6,6 x 1,3 cm (DX157-2300)
200 x 6,6 x 1,3 cm (DX157F)
Duropolymer®



SX165 | SX165F

AXXENT

200 x 6,9 x 1,1 cm
Duropolymer®



SX125

AXXENT

200 x 6,9 x 1,4 cm
Duropolymer®



SX122

AXXENT

200 x 7,9 x 2,2 cm
Duropolymer®





SX137

AXXENT

200 x 9,9 x 1,5 cm
Duropolymer[®]

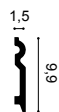

DX163-2300

AXXENT

230 x 10,2 x 1,3 cm
Duropolymer[®]

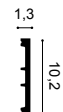

SX105 | SX105F

LUXXUS

200 x 10,8 x 1,3 cm
Duropolymer[®]



SX155 | SX155F

LUXXUS

200 x 10,8 x 2,5 cm
Duropolymer[®]



1 SX118

p. 116

1



SX138

AXXENT

200 x 13,8 x 1,5 cm
Duropolymer[®]



SX118 | SX118F

LUXXUS

200 x 13,8 x 1,8 cm
Duropolymer[®]



SX104

LUXXUS

200 x 14,8 x 1,7 cm
Duropolymer[®]



DX168-2300

AXXENT

230 x 15,1 x 1,4 cm
Duropolymer[®]

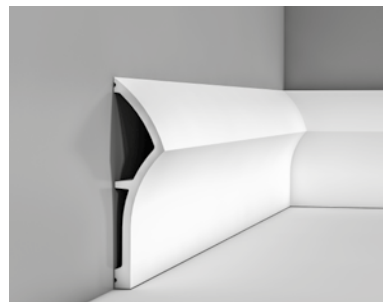

SX167 DUNE

ULF MORITZ

200 x 17,3 x 4,3 cm
Duropolymer[®]
Designed by Ulf Moritz



SX156 HIGH HEELS

LUXXUS

200 x 20 x 1,6 cm
Duropolymer[®]
Designed by
Xavier Donck



ORAC FLEX (REF + F)

Battiscopa / Plinte / Skirting / Podlahové lišty / Rodapés

ORAC[®]
DECOR



LUXXUS cm

R min

SX105F 30

SX118F 40

SX155F 30

AXXENT cm

R min

R* min

CX132F 70

DX157F 35 260

SX165F 40

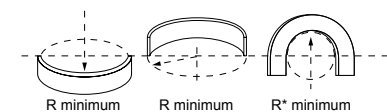



it

Indispensabile per l'atmosfera, l'illuminazione indiretta crea un'illusione di spazio aggiuntivo. Che sia lineare o diffusa, con la luce rivolta verso il basso o verso l'alto, l'illuminazione indiretta sottolinea senza dubbio l'architettura degli interni. Grazie all'illuminazione a LED compact, si ha a disposizione una soluzione economica e di lunga durata.

ro

Iluminatul indirect confera o atmosfera calda si creeaza un efect de mai mult spatiu. Fie ca este rectiliniu sau difuz, in sus sau in jos, un lucru este clar: acesta imbunatateste arhitectura. Si mai mult, iluminatul cu LED asigura o solutie energetica eficienta si durabila.

en

Indirect lighting imparts a warm atmosphere and creates an extra spatial effect. Whether tautly linear or diffuse, as uplight or downlight, one thing is certain: it enhances the architecture. What's more, the compact LED lighting ensures an energy-efficient and durable solution.

cz

Nepřímé osvětlení navozuje příjemnou atmosféru a vytváří efekt většího prostoru. Ať je přímočaře lineární nebo difúzní, instalované jako horní nebo spodní osvětlení, jedno je jisté: zvýrazňuje architekturu. A co víc, kompaktní LED osvětlení poskytuje úsporné a trvanlivé řešení.

pt

A iluminação indireta proporciona um ambiente acolhedor e cria um efeito de espaço. Seja linear ou difusa, de cima ou de baixo, uma coisa é clara: realça a arquitetura do espaço interior. Além disso, os LED de iluminação compacta garante uma solução eficiente em termos de energia e durabilidade.

Illuminazione Indiretta
Iluminatul indirect
Indirect Lighting
Nepřímé osvětlení
Iluminação Indireta

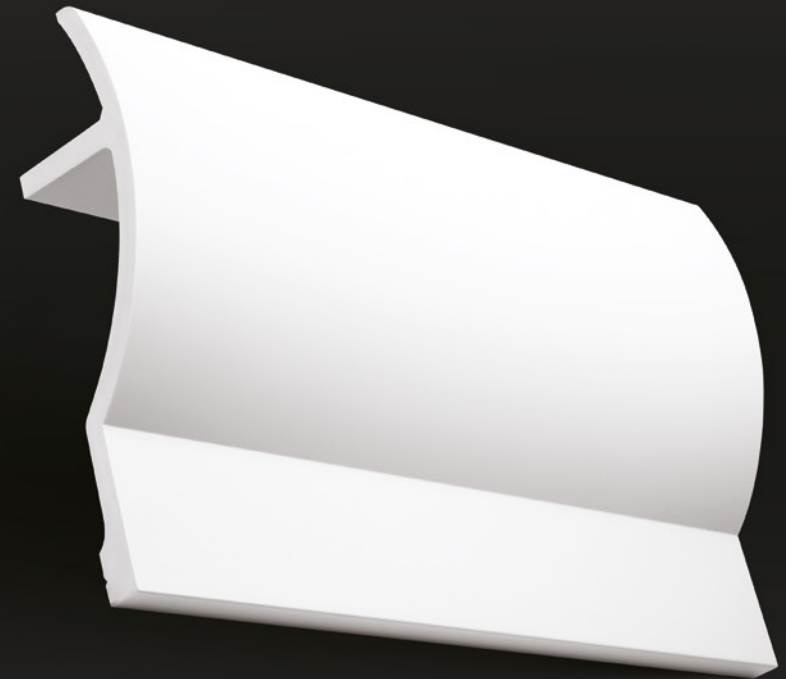



C351 BOAT

LUXXUS

200 x 7,4 x 17,3 cm

Purotouch[®]

Designed by
Jacques Vergracht

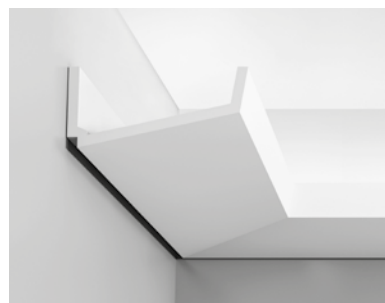
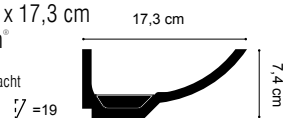

C352 FLAT

LUXXUS

200 x 7,6 x 17,1 cm

Purotouch[®]

Designed by
Jacques Vergracht

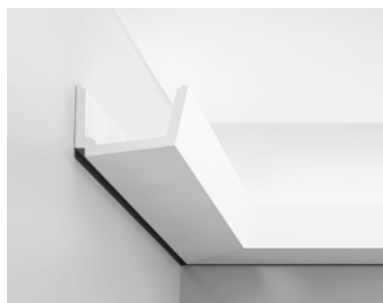

C357 STRAIGHT

LUXXUS

200 x 7,1 x 11 cm

Purotouch[®]

Designed by
Jacques Vergracht

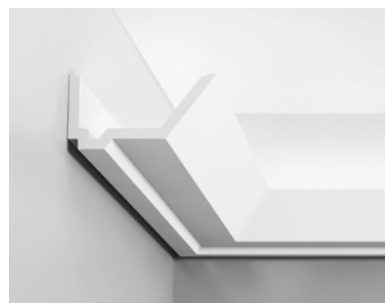
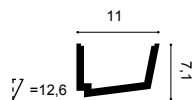

C358 RAIL

LUXXUS

200 x 7,3 x 14 cm

Purotouch[®]

Designed by
Jacques Vergracht

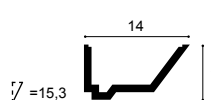



1 C364 WAVE p. 121



C361 STRIPE

LUXXUS

200 x 5 x 5 cm
 Purotouch®
 Designed by
 Pierre Daems

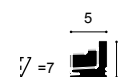

C364 WAVE

LUXXUS

200 x 14 x 8 cm
 Purotouch®
 Designed by
 Pierre Daems
 Red Dot Design Award 2014

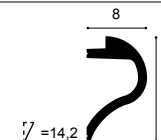

C362 CURVE

LUXXUS

200 x 5 x 5 cm
 Purotouch®
 Designed by
 Pierre Daems

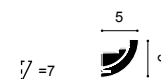



- ❶ C991 *p. 70*
- ❷ C374 ANTONIO *p. 123*
- ❸ C373 ANTONIO *p. 123*
- ❹ SX167 DUNE *p. 116*



❶ C373 ANTONIO *p. 123*

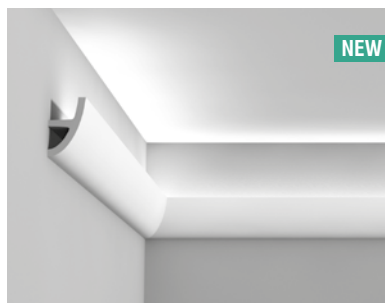

NEW

C373 | C373F ANTONIO ULF MORITZ

200 x 8 x 5 cm
 Purotouch[®]
 Designed by
 Ulf Moritz

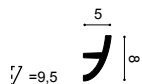

NEW

C374 | C374F ANTONIO ULF MORITZ

200 x 18 x 5 cm
 Purotouch[®]
 Designed by
 Ulf Moritz

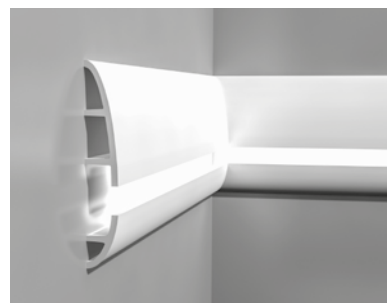
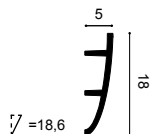

C374 ANTONIO + C373 ANTONIO

Soffitto / Plafon / Ceiling / Strop / Teto

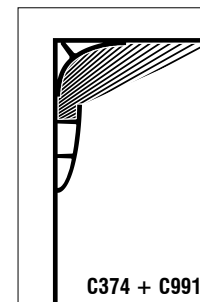
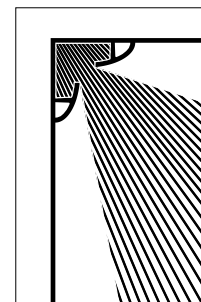
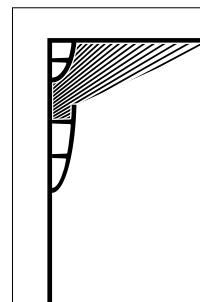

C374 + C991

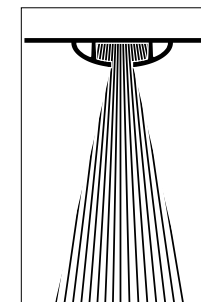

Parete / Perete / Wall / Stěna / Parede

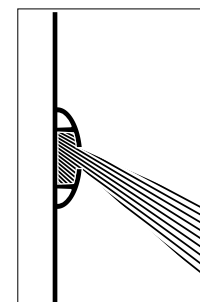
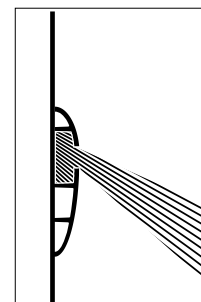
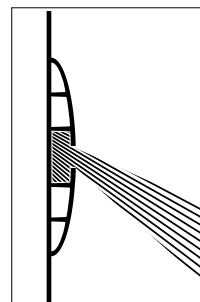

Pavimento / Sol / Floor / Podlaha / Suelo

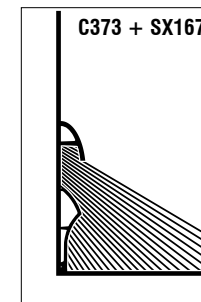
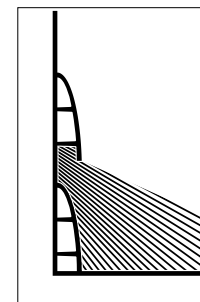
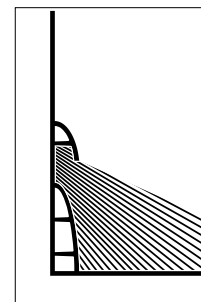
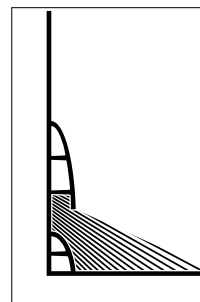

C373 + SX167





- ❶ C371 SHADE *p. 125*
- ❷ C374 ANTONIO *p. 123*
- ❸ C373 ANTONIO *p. 123*



NEW

C991

ULF MORITZ

200 x 11 x 14 cm
 Purotouch[®]
 Designed by
 Ulf Moritz

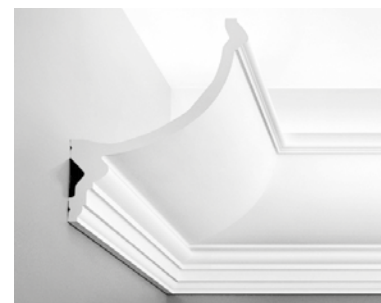
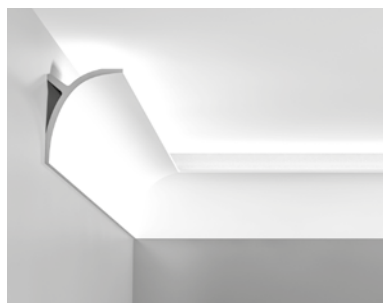
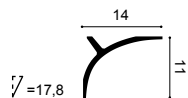

C900

LUXXUS

200 x 17,1 x 14,6 cm
 Purotouch[®]

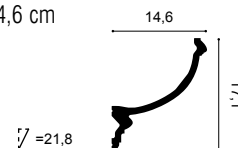

C901

LUXXUS

200 x 14,8 x 12,4 cm
 Purotouch[®]

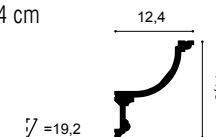

C371 SHADE

ULF MORITZ

200 x 18,5 x 5,8 cm
 Purotouch[®]
 Designed by
 Ulf Moritz

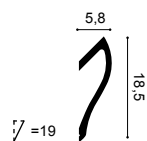

C372 FLUXUS

ULF MORITZ

200 x 28 x 7 cm
 Purotouch[®]
 Designed by
 Ulf Moritz

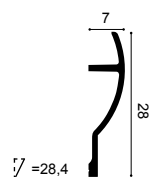

C902

LUXXUS

200 x 10,3 x 10,3 cm
 Purotouch[®]

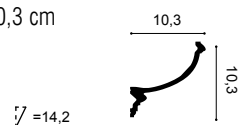

LIGHTING TIPS !





it

Lasciate libera la vostra immaginazione. Se siete alla ricerca di un risultato sobrio ed elegante per un interno classico, di una finitura moderna per una casa contemporanea o di un originale effetto in 3D, avete trovato la soluzione giusta. Gli elementi decorativi proposti consentono infinite opportunità per rendere unico ogni ambiente.

ro

Urmeaza-ti imaginatia. Un interior sobru si clasic poate fi creat cu elementele noastre Deco. Pot fi adaugate elemente 3D intr-o casa cu desing contemporan? Elementele acestor decoratiuni permit personalizarea oricarei camere.

en

Follow your imagination. Understated and dignified classic interiors, can be created with our Deco elements. The sleek, modern designs suit contemporary homes, by adding a dramatic 3D form? The elements of these ornaments allow considerable opportunities to personalize any room.

cz

Následujte svou představivost. S pomocí našich dekorativních prvků je možné vytvořit umírněné i důstojné klasické interiéry. Je možné doplnit hladké, moderní designy současných domovů dramatickými 3D tvary? Prvky těchto ornamentů poskytují mnoho možností k přizpůsobení se libovolné místnosti.

pt

Siga a sua imaginação. Procura interiores elegantes e dignificantes num ambiente clássico, simples e contemporâneo num apartamento moderno ou prefere um design 3D de fantasia? Todos estas opções podem ser criadas com os nossos elementos decorativos. Os designs elegantes e modernos podem ser adequados a casas contemporâneas ou o inverso. Os elementos decorativos permitem oportunidades consideráveis para personalizar cada espaço, tornando cada decoração única.

Elementi Decorativi
Elemente decorative
Deco Elements
Dekoratívní prvky
Elementos Decorativos



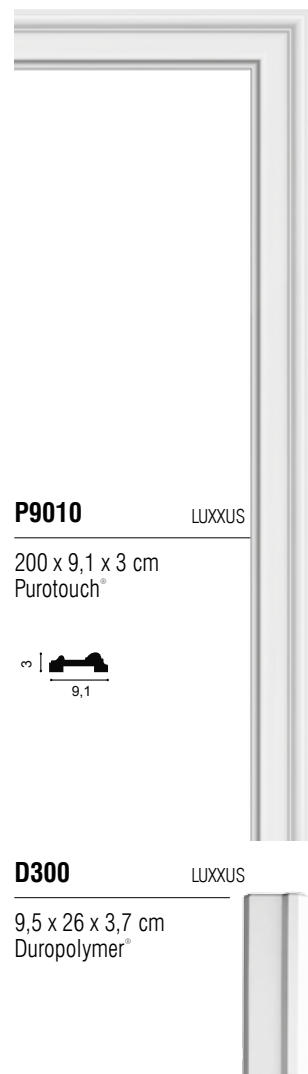

P9010 LUXXUS

200 x 9,1 x 3 cm
 Purotouch[®]



NEW

DX170-2300 LUXXUS

230 x 11,9 x 3,2 cm
 Duropolymer[®]

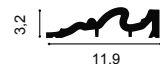

NEW

D330LR LUXXUS

12,6 x 16 x 4,1 cm
 Duropolymer[®]



D210 LUXXUS

9,6 x 9,6 x 3,5 cm
 Duropolymer[®]

DX121-2300 LUXXUS

230 x 9,4 x 2,3 cm
 Duropolymer[®]

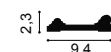

D310 LUXXUS

9,5 x 24,9 x 3,1 cm
 Duropolymer[®]

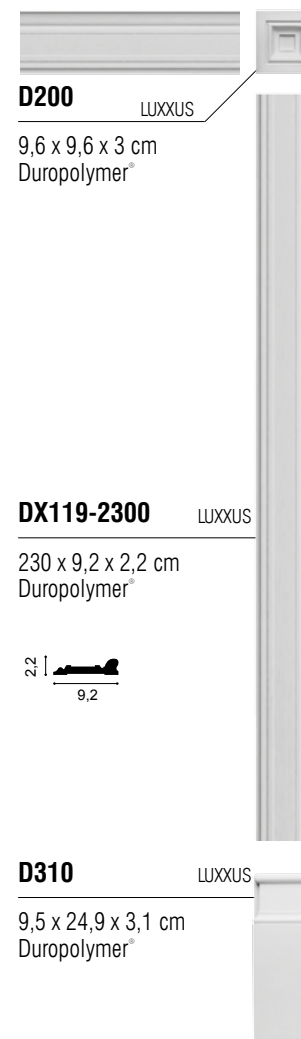

D200 LUXXUS

9,6 x 9,6 x 3 cm
 Duropolymer[®]

DX119-2300 LUXXUS

230 x 9,2 x 2,2 cm
 Duropolymer[®]

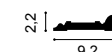

D310 LUXXUS

9,5 x 24,9 x 3,1 cm
 Duropolymer[®]

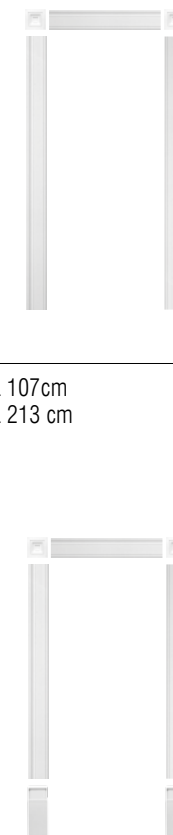

KIT KX001

1 x DX119, L 107cm
 2 x DX119, L 213 cm
 2 x D200

KIT KX003

1 x DX119, L 107cm
 2 x DX119, L 190 cm
 2 x D200
 2 x D310

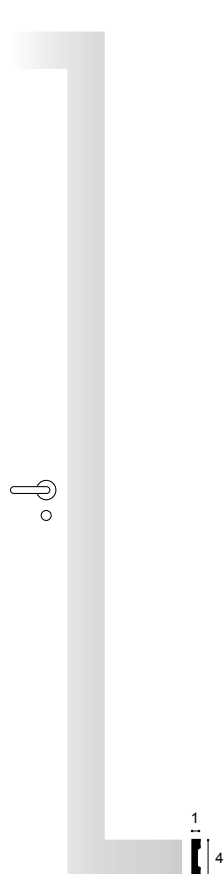

DX162-2300

AXXENT

230 x 4 x 1 cm
 Duropolymer[®]

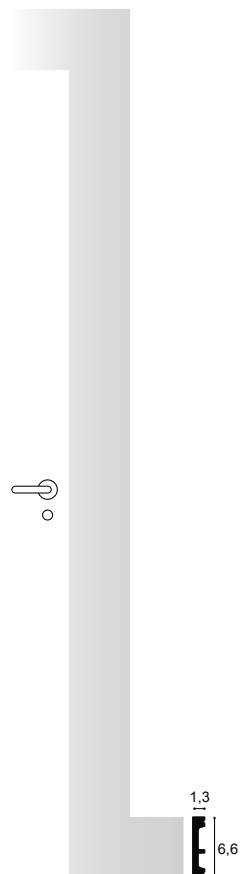

DX157-2300

AXXENT

230 x 6,6 x 1,3 cm
 Duropolymer[®]

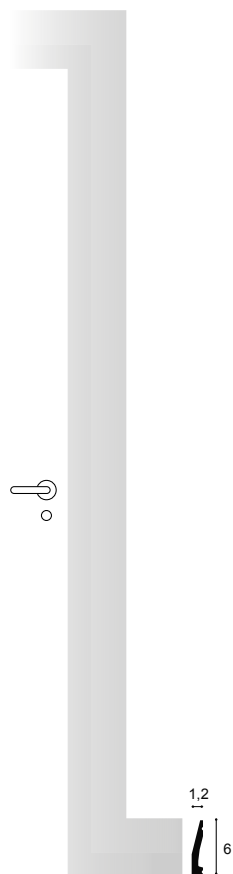

DX159-2300

AXXENT

230 x 6 x 1,2 cm
 Duropolymer[®]

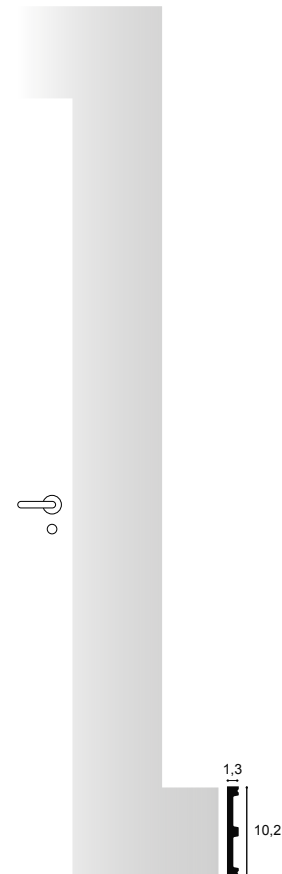

DX163-2300

AXXENT

230 x 10,2 x 1,3 cm
 Duropolymer[®]

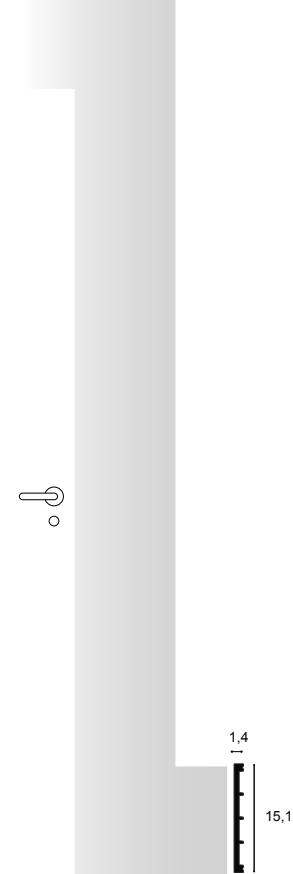

DX168-2300

AXXENT

230 x 15,1 x 1,4 cm
 Duropolymer[®]



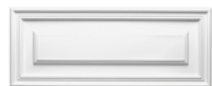

D504

LUXXUS

55 x 22 x 1,7 cm
Duropolymer[®]



F30

LUXXUS

59,5 x 59,5 x 4,3 cm
Purotouch[®]

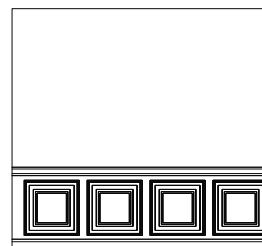

P9010
F30
SX118

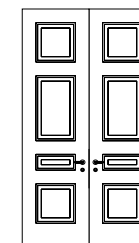

D503
D507
D504
D503

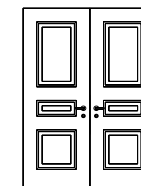

D507
D504
D503



D500

LUXXUS

55 x 74,7 x 1,6 cm
Duropolymer[®]

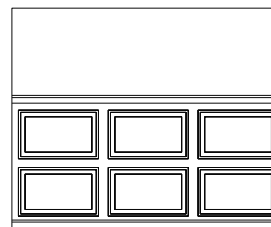

P8050
D507
SX156

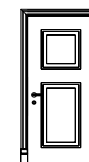

DX121-2300 + D310
D503
D507

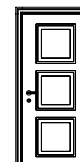

DX119-2300
3x D503



D503

LUXXUS

55 x 55 x 1,7 cm
Duropolymer[®]



D507

LUXXUS

55 x 90,5 x 1,7 cm
Duropolymer[®]



D506

LUXXUS

43 x 43 x 1,7 cm
Duropolymer[®]

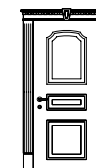

D401 + D402
2x K200 + D320
D500
D504
D503

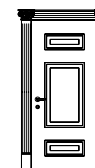

K201L + K200 + K201R
2x K200
D504
D507
D504
D504
D320



PX147

AXXENT

200 x 16,9 x 0,9 cm
Duropolymer[®]

A

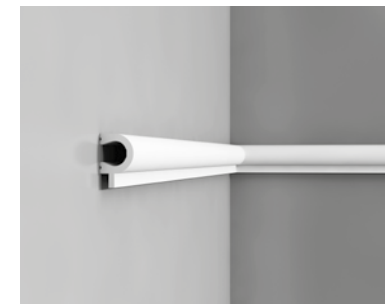

PX169

AXXENT

200 x 5,5 x 3,4 cm
Duropolymer[®]

B



PX147 + PX169

A + B

Frontoni / Frontoane /
Pediments / Římsy / Frontões



D140

LUXXUS

98,5 x 31,5 x 2,5 cm
Purotouch[®]



D120

LUXXUS

124 x 25 x 9 cm
Purotouch[®]



D402

LUXXUS

15 x 12,1 x 5,8 cm
Purotouch[®]
(only for D400 and D401)



D161

LUXXUS

92 x 23 x 3,7 cm
Purotouch[®]



D400

LUXXUS

127,5 x 14,5 x 5,5 cm
Purotouch[®]

D400 + D402



D170

LUXXUS

105 x 24,5 x 3,2 cm
Purotouch[®]



D401

LUXXUS

127,5 x 14,5 x 5,5 cm
Purotouch[®]

2 x D401 + D402



Decorazioni Camino / Seminee Decorative / Decorative Mantel Pieces / Dekorativní krbové římsy / Lareira decorativa

Nicchie / Nise / Niches / Niky / Nichos

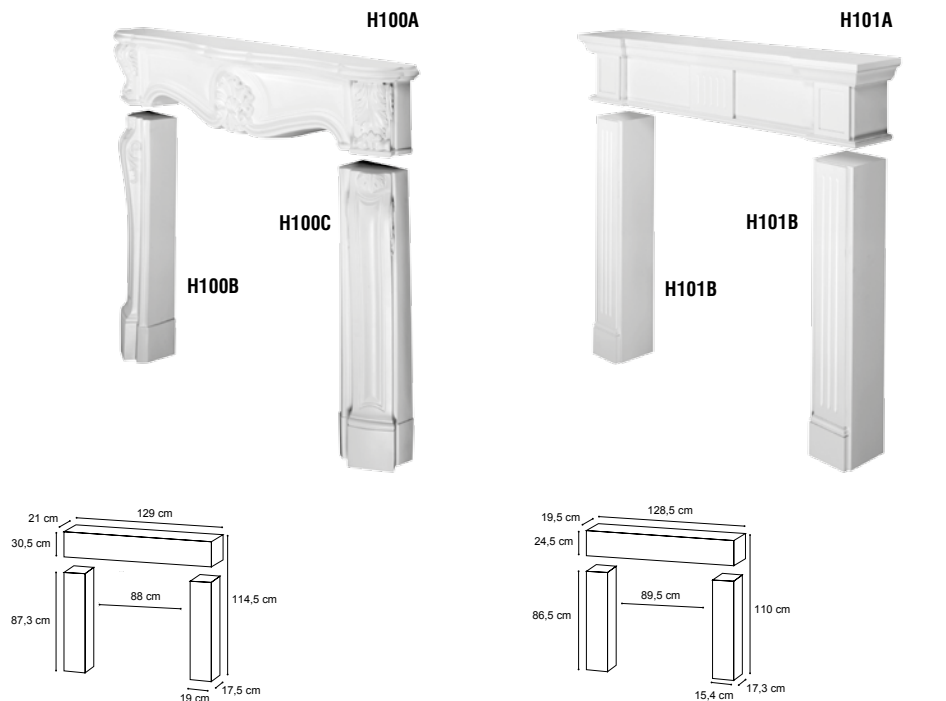

H100

LUXXUS

114,5 x 129 x 21 cm
Purotouch®

H101

LUXXUS

110 x 128,5 x 19,5 cm
Purotouch®

N503

1 LUXXUS

69,5 x 113,5 x 11,1 cm
Purotouch®

N504

2 LUXXUS

69,5 x 114 x 10,9 cm
Purotouch®

N510

3 LUXXUS

55,3 x 98,5 x 18 cm
Purotouch®

N520

4 LUXXUS

55,5 x 98,5 x 18 cm
Purotouch®

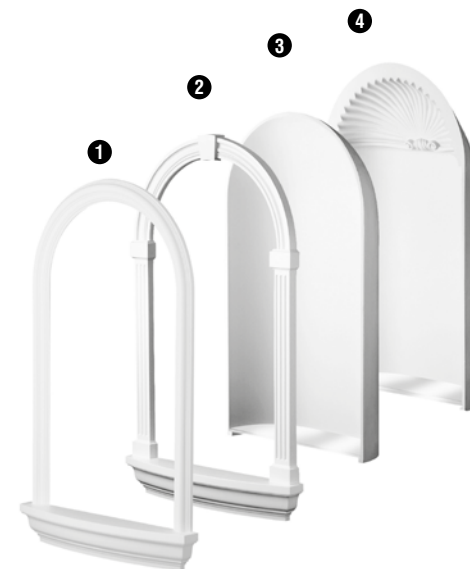

(cm)	A	B	C	AA	
N503	69,5	113,5	11,1	51,5	
N504	69,5	114,0	10,9	49,5	
(cm)	F	G	H	FF	GG
N510	55,3	98,5	18,0	53,0	96,0
N520	55,5	98,5	18,0	53,0	92,0

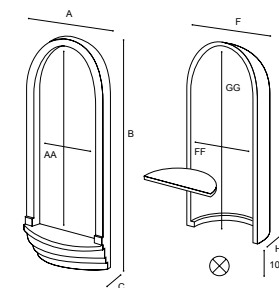

max. 2 à 3 kW

Le decorazioni camino sono elementi decorativi. Devono essere utilizzate solo con fuoco elettrico da 2 a 3 kW max.
Semineele sunt elemente decorative. Pot fi instalate doar cu foc electric de max. 2-3kW.
The fireplaces are just as decorative purposes and should only be installed in conjunction with an electric heater up to 2 to 3 kW.
Krbové římsy slouží jen k dekorativním účelům a instalují se pouze u elektrických krbů s max. výkonem 2 až 3 kW.
As lareiras são apenas elementos decorativos e deverão ser instaladas com sistemas de aquecimentos elétrico de potência máxima de 2-3 Kw.

Installare la lampadina (max. 60W) ad un minimo di 10 cm di profondità dal piano opaco.
Instalati becul (max. 60W) la cel puțin 10cm - fond opal.
Place the bulb (max. 60W) at least 10cm from bottom plate.
Žárovku (max. 60 W) umístěte nejméně 10 cm od opalového skla.
Instale a lâmpada (max. 60W) a pelo menos 10 cms da base opaca.

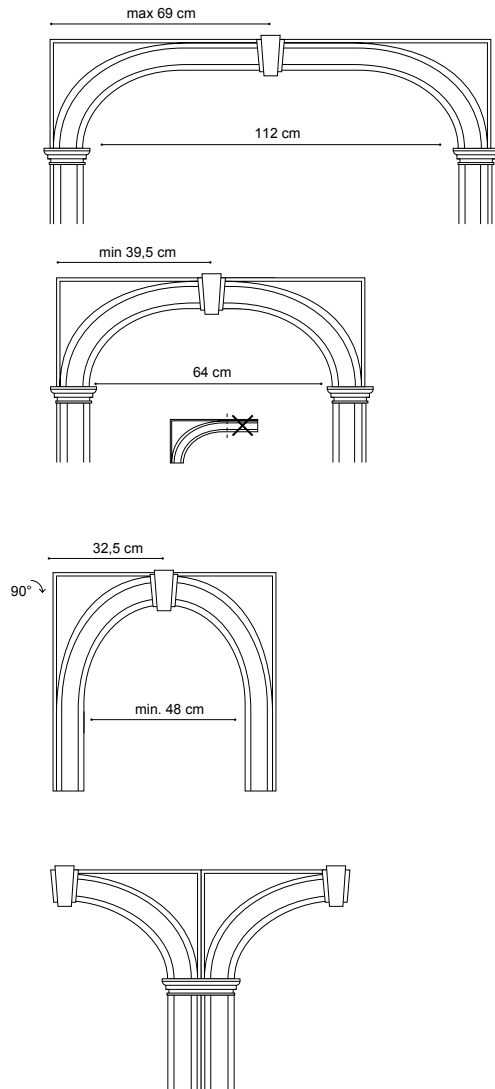

M9010LR

64,2 x 32 x 3 cm
Duropolymer[®]

P9010

200 x 9,1 x 3 cm
Purotouch[®]

D300

9,5 x 26 x 3,7 cm
Duropolymer[®]

M9010R

LUXXUS

M9010L

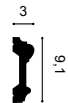

LUXXUS

LUXXUS

M9010A

LUXXUS

LUXXUS

LUXXUS

LUXXUS

P9010

M9010C

22,5 x 5,2 x 4,9 cm
Duropolymer[®]

M9010B

12,6 x 5,2 x 4,9 cm
Duropolymer[®]

M9010A

9,5 x 4,5 x 11,6 cm
Duropolymer[®]

D310

8,5 x 24,9 x 3,1 cm
Duropolymer[®]

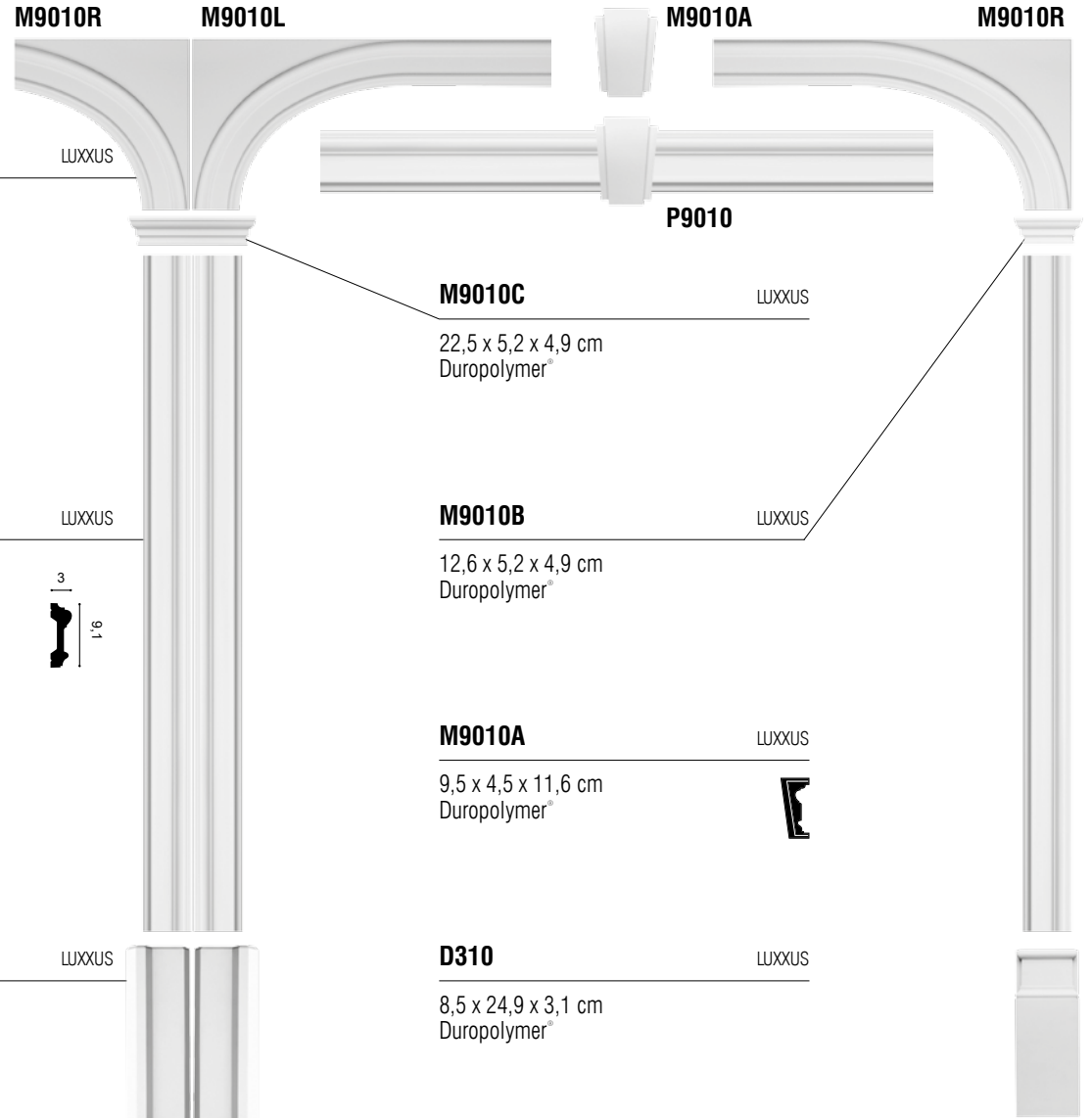

Byblos

Lampade a muro / Applicatii / Fixtures Osvětlovací prvky / Appliques de parede

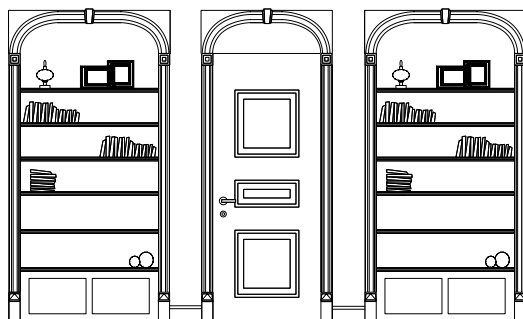

M9010L, M9010A, M9010R
D200, P9010, D300, D503, D504, SX118

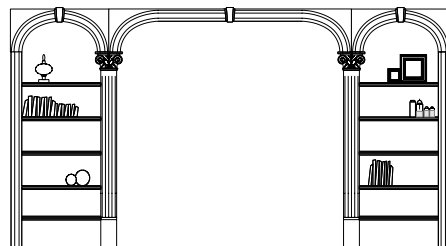

M9010L, M9010A, M9010R
K200, K201, D320

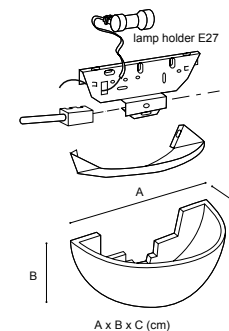

L504

LUXXUS

30,5 x 15,3 x 15 cm
Duropolymer®

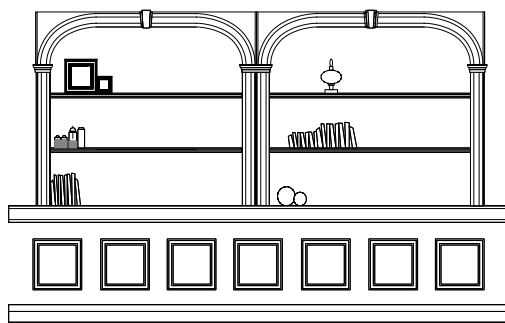

M9010L, M9010A, M9010R, M9010B, M9010C
P9010, P9020, D506, SX105

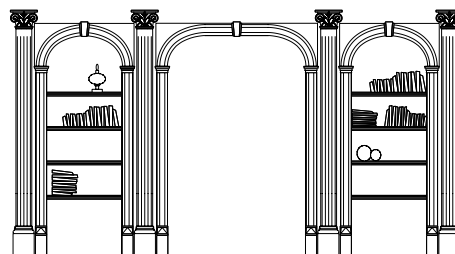

M9010L, M9010A, M9010R, M9010B
K201, K200, K202, P9010, D310



L505

LUXXUS

40,8 x 11,5 x 16,3 cm
Duropolymer®

Rosoni / Rozete /
Ceiling Roses / Rozety / Centros de teto

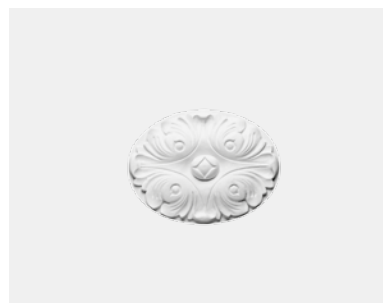
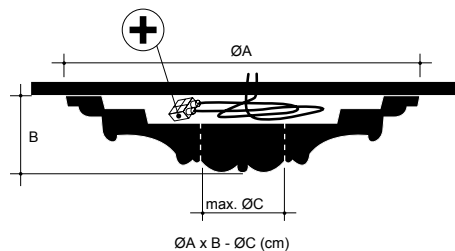

D62 LUXXUS

15,6 x 11,6 x 1,4 cm
Purotouch[®]

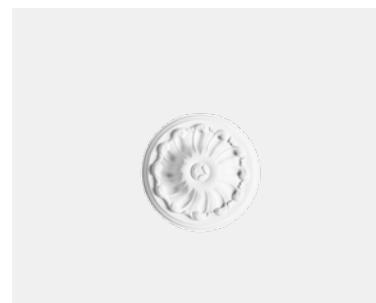

R10 LUXXUS

ø 15 x 4,2 - ø 2 cm
Purotouch[®]



R11 LUXXUS

ø 19 x 3,6 - ø 3 cm
Purotouch[®]

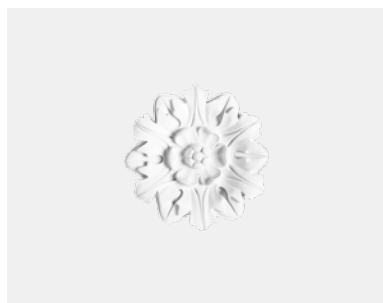

R12 LUXXUS

ø 19,5 x 1,8 - ø 1 cm
Purotouch[®]

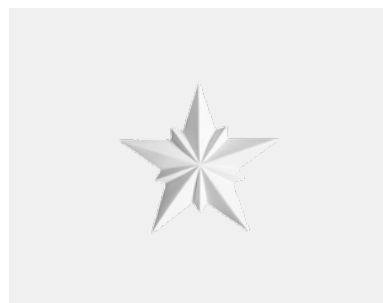

R35 LUXXUS

ø 20,5 x 2,7 cm
Purotouch[®]

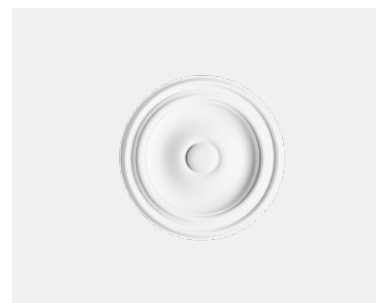

R07 LUXXUS

ø 26 x 3 - ø 5 cm
Purotouch[®]

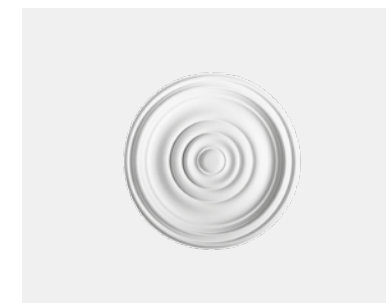

R08 LUXXUS

ø 38 x 4,2 - ø 5 cm
Purotouch[®]

Rosoni / Rozete /
Ceiling Roses / Rozety / Centros de teto



R13 LUXXUS

ø 28 x 3,1 - ø 2,5 cm
Purotouch[®]



R50 LUXXUS

ø 32 x 3,8 - ø 19 cm
Purotouch[®]

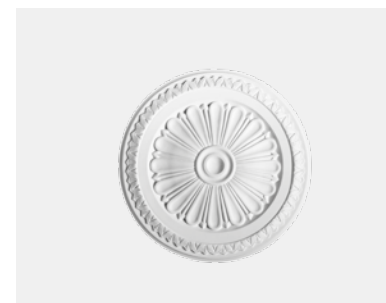

R14 LUXXUS

ø 33 x 3 - ø 2,5 cm
Purotouch[®]



R31 LUXXUS

ø 38,5 x 2,7 - ø 3,5 cm
Purotouch[®]



R61 LUXXUS

ø 40 x 3,1 - ø 2,5 cm
Purotouch[®]



R17 LUXXUS

ø 47 x 3,5 - ø 6,5 cm
Purotouch[®]

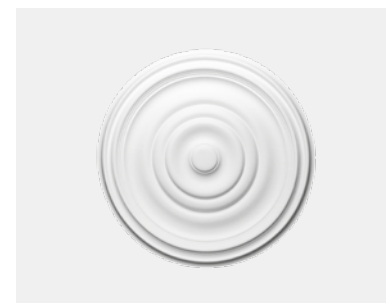

R09 LUXXUS

ø 48,5 x 3,7 - ø 6 cm
Purotouch[®]



R18 LUXXUS

ø 49 x 4,7 - ø 7 cm
Purotouch[®]

Rosoni / Rozete /
Ceiling Roses / Rozety / Centros de teto



R46 LUXXUS

ø 53,5 x 4,2 - ø 3 cm
Purotouch[®]



R66 LUXXUS

ø 54,5 / 43 x 2,4 cm
Purotouch[®]

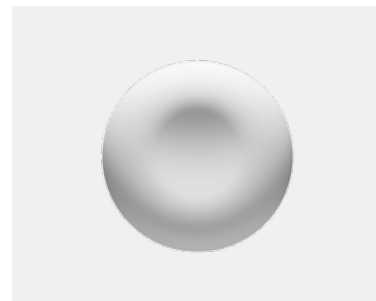

R70 ULF MORITZ

ø 60 x 7,7 cm
Purotouch[®]



6x G77 LILY ULF MORITZ

ø 50 cm / G77: 19,4 x 8,8 x 1,8 cm
Duropolymer[®]



R76 LUXXUS

ø 62 x 4,1 - ø 10,5 cm
Purotouch[®]



R77 LUXXUS

ø 62 x 4,2 - ø 10,5 cm
Purotouch[®]

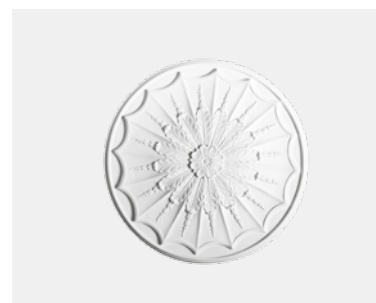

R28 LUXXUS

ø 68,5 x 5,2 - ø 2 cm
Purotouch[®]

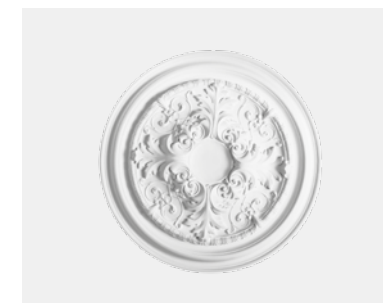

R52 LUXXUS

ø 69,5 x 4,8 - ø 12,5 cm
Purotouch[®]



Rosoni / Rozete /
Ceiling Roses / Rozety / Centros de teto



R73 LUXXUS

ø 70 x 5,9 - ø 8 cm
Purotouch[®]



R38 LUXXUS

ø 71 x 4,2 - ø 19 cm
Purotouch[®]



R23 LUXXUS

ø 71 x 4,4 - ø 6 cm
Purotouch[®]



R40 LUXXUS

ø 74,5 x 3,1 - ø 10 cm
Purotouch[®]



R27 LUXXUS

ø 75 x 4,5 - ø 9 cm
Purotouch[®]



R22 LUXXUS

77,5 x 53 x 3,6 cm
Purotouch[®]



R24 LUXXUS

ø 79 x 6 - ø 8 cm
Purotouch[®]



R64 LUXXUS

ø 95,2 x 4,8 - ø 7 cm
Purotouch[®]



Decorazione Soffitto / Ornamente decorative pentru tavan /
Ceiling Ornaments / Stropní dekorativní prvky / Decorações para teto



F30 LXXXUS

59,5 x 59,5 x 4,3 cm
Purotouch[®]

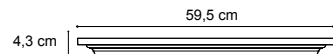

F12 LXXXUS

34 x max. diam. 133,5 cm
Purotouch[®]

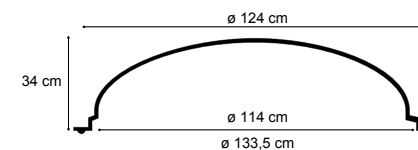

F31 LXXXUS

59,5 x 59,5 x 6,6 cm
Purotouch[®]

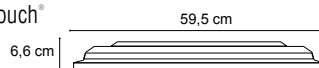

F10 LXXXUS

11,2 x max. diam. 90 cm
Purotouch[®]

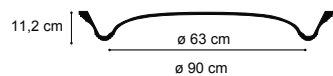

F11 LXXXUS

9,5 x max. diam. 74,5 cm
Purotouch[®]

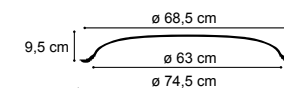

Elementi Decorativi / Elemente decorative
Deco Elements / Dekorativní prvky / Elementos Decorativos



G40

LUXXUS

16,4 x 13,4 x 1,5 cm
Duropolymer[®]



D200

LUXXUS

9,6 x 9,6 x 3 cm
Duropolymer[®]



D210

LUXXUS

9,6 x 9,6 x 3,5 cm
Duropolymer[®]



P5020B

LUXXUS

9 x 9 x 1,3 cm
Purotouch[®]



G42

LUXXUS

39,8 x 4,4 x 1,9 cm
Duropolymer[®]



P21

LUXXUS

6,7 x 6,7 x 0,9 cm
Duropolymer[®]

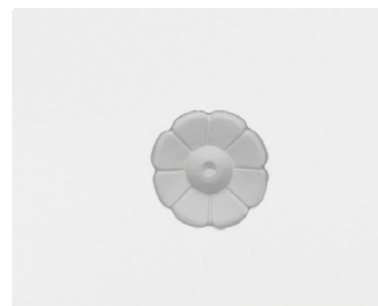

P20

LUXXUS

Ø 6,1 - 0,8 cm
Duropolymer[®]

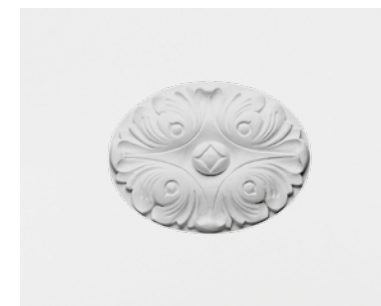

D62

LUXXUS

15,6 x 11,6 x 1,4 cm
Purotouch[®]



G70 FOLIO

ULF MORITZ

20 x 9 x 2,7 cm
 Duropolymer[®]

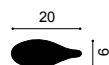

G72 SMILE

ULF MORITZ

42,5 x 6,8 x 1 cm
 Duropolymer[®]

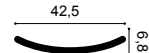

G78 LILY

ULF MORITZ

8,8 x 4,4 x 1,9 cm
 Duropolymer[®]



G77 LILY

ULF MORITZ

19,4 x 8,8 x 1,8 cm
 Duropolymer[®]



G73L CURL MINI

ULF MORITZ

20,1 x 18,1 x 1 cm
 Purotouch[®]

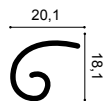

G73R CURL MINI

ULF MORITZ

20,1 x 18,1 x 1 cm
 Purotouch[®]



G74L CURL MAXI

ULF MORITZ

25,4 x 24,4 x 1,1 cm
 Purotouch[®]

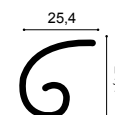

G74R CURL MAXI

ULF MORITZ

25,4 x 24,4 x 1,1 cm
 Purotouch[®]

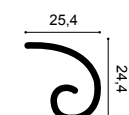

Elementi Decorativi / Elemente decorative
Deco Elements / Dekorativní prvky / Elementos Decorativos



G71 SCALA

ULF MORITZ

42,2 x 35 x 1,5 cm
Purotouch®

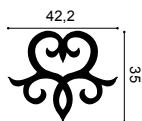

G76 SCALA

ULF MORITZ

8 x 17,8 x 1,5 cm
Purotouch®

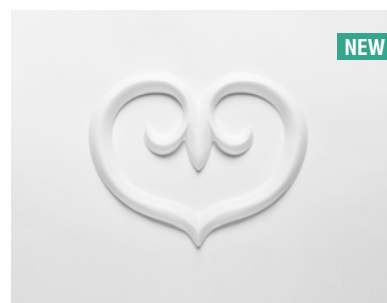

G75 SCALA

ULF MORITZ

27 x 21 x 1,4 cm
Purotouch®



Colonne Segmentate /
Segmente de coloane / Segmented Columns /
Segmentové sloupy / Colunas Segmentadas

K4132 (H 21,5 cm)



5 x K4002 (H 72 cm)

4 x K4002 (H 72 cm)

3 x K4002 (H 72 cm)

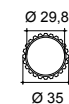

K4132 + 3xK4002 + K4122 = 274 cm H max
K4132 + 4xK4002 + K4122 = 345 cm H max
K4132 + 5xK4002 + K4122 = 416 cm H max

K4122 (H 40cm)

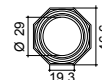

K4131 (H 21,5 cm)



5 x K4001 (H 72 cm)

4 x K4001 (H 72 cm)

3 x K4001 (H 72 cm)



K4131 + 3xK4001 + K4121 = 274 cm H max
K4131 + 4xK4001 + K4121 = 345 cm H max
K4131 + 5xK4001 + K4121 = 416 cm H max

K4121 (H 40 cm)



Colonne Intere / Coloane intregi / Full Columns / Plné sloupy / Colunas completas

K1142 (H 16 cm)



K1142 (H 16 cm)

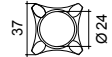

K1112 (H 30 cm)



K1112 (H 30 cm)

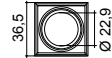

K1122 (H 30 cm)

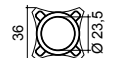

K1122 (H 30 cm)

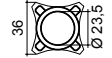

K1002 (H 199,5 cm)



K1102 (H 202 cm)



K3142 (H 20 cm)



K3142 (H 20 cm)



K3142 (H 20 cm)



K3112 (H 12,5 cm)

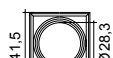

K3112 (H 12,5 cm)



K3112 (H 12,5 cm)

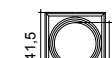

K3002 (H 201 cm)

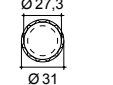

K3102 (H 202 cm)

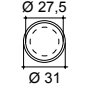

K3202 (H 241,5 cm)

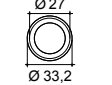

K1142 + K1002 + K1152 = 225 cm H
K1142 + K1002 + K1132 = 270 cm H max
K1112 + K1002 + K1152 = 242 cm H
K1112 + K1002 + K1132 = 287 cm H max
K1122 + K1002 + K1152 = 242 cm H
K1122 + K1002 + K1132 = 287 cm H max

K1142 + K1102 + K1152 = 227,5 cm H
K1142 + K1102 + K1132 = 272,5 cm H max
K1112 + K1102 + K1152 = 244,5 cm H
K1112 + K1102 + K1132 = max. 289,5 cm H max
K1122 + K1102 + K1152 = 244,5 cm H
K1122 + K1102 + K1132 = 289,5 cm H max

K3142 + K3002 + K2132 = 237 cm H
K3142 + K3002 + K3152 = 275 cm H max
K3112 + K3002 + K2132 = 233,5 cm H
K3112 + K3002 + K3152 = 271,5 cm H max

K3142 + K3102 + K2132 = 237 cm H
K3142 + K3102 + K3152 = 275 cm H max
K3112 + K3102 + K2132 = 233,5 cm H
K3112 + K3102 + K3152 = 271,5 cm H max

K3142 + K3202 + K2132 = 277,5 cm H
K3142 + K3202 + K3152 = 315,5 cm H max
K3112 + K3202 + K2132 = 274 cm H
K3112 + K3202 + K3152 = 312 cm H max

K1152 (H 12,5 cm)

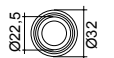

K1152 (H 12,5 cm)

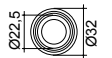

K1132 (H 57,5 cm)

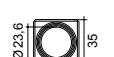

K1132 (H 57,5 cm)



K2132 (H 20 cm)



K2132 (H 20 cm)



K2132 (H 20 cm)



K3152 (H 58 cm)

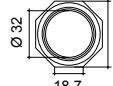

K3152 (H 58 cm)

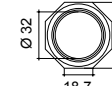

K3152 (H 58 cm)

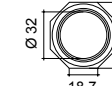

Mezze Colonne / Coloane jumatati / Half Columns / Poloviční sloupy / Meias Colunas

K1141 (H 16 cm)



K1111 (H 30 cm)



K1121 (H 30 cm)



K1101 (H 199,5 cm)



K1141 + K1001 + K1151 = 225 cm H
K1141 + K1001 + K1131 = 270 cm H max
K1111 + K1001 + K1151 = 242 cm H
K1111 + K1001 + K1131 = 287 cm H max
K1121 + K1001 + K1151 = 242 cm H
K1121 + K1001 + K1131 = 287 cm H max

K1141 (H 16 cm)



K1111 (H 30 cm)



K1121 (H 30 cm)



K1101 (H 202 cm)



K1141 + K1101 + K1151 = 227,5 cm H
K1141 + K1101 + K1131 = 272,5 cm H max
K1111 + K1101 + K1151 = 244,5 cm H
K1111 + K1101 + K1131 = max. 289,5 cm H max
K1121 + K1101 + K1151 = 244,5 cm H
K1121 + K1101 + K1131 = 289,5 cm H max

K3141 (H 20 cm)



K3111 (H 12,5 cm)



K3001 (H 201 cm)



K3141 + K3001 + K2131 = 237 cm H
K3141 + K3001 + K3151 = 275 cm H max
K3111 + K3001 + K2131 = 233,5 cm H
K3111 + K3001 + K3151 = 271,5 cm H max

K3141 (H 20 cm)



K3111 (H 12,5 cm)



K3101 (H 202 cm)



K3141 + K3101 + K2131 = 237 cm H
K3141 + K3101 + K3151 = 275 cm H max
K3111 + K3101 + K2131 = 233,5 cm H
K3111 + K3101 + K3151 = 271,5 cm H max

K3141 (H 20 cm)



K3111 (H 12,5 cm)



K3201 (H 241,5 cm)

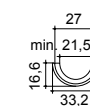

K3141 + K3201 + K2131 = 277,5 cm H
K3141 + K3201 + K3151 = 315,5 cm H max
K3111 + K3201 + K2131 = 274 cm H
K3111 + K3201 + K3151 = 312 cm H max

K1151 (H 12,5 cm)



K1131 (H 57,5 cm)



K1151 (H 12,5 cm)



K1131 (H 57,5 cm)



K2131 (H 20 cm)



K3151 (H 58 cm)



K2131 (H 20 cm)



K3151 (H 58 cm)



K2131 (H 20 cm)



K3151 (H 58 cm)



Pilastri / Pilastri / Pilasters / Pilastry / Pilastras

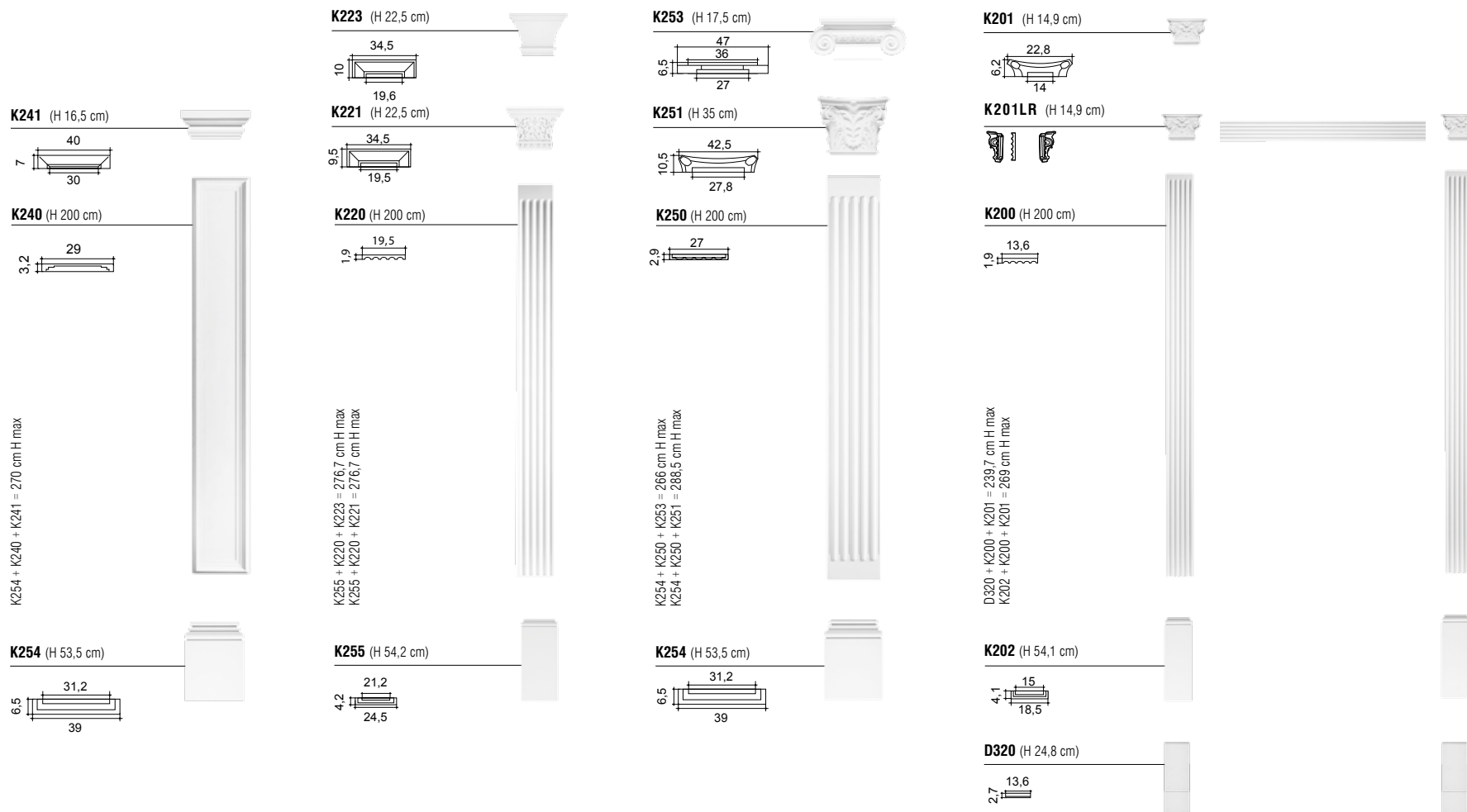

Consoles-Mensole / Console / Corbels / Konzole / Mensulas

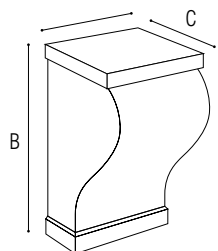

A x B x C (cm)



B401 LUXXUS

11,6 x 15,4 x 7 cm
Purotouch[®]

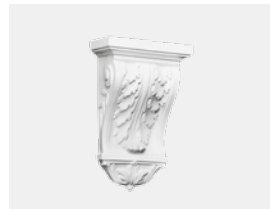

B404 LUXXUS

19,3 x 31,5 x 11,3 cm
Purotouch[®]

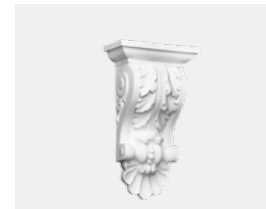

B408 LUXXUS

21,5 x 39 x 12,6 cm
Purotouch[®]

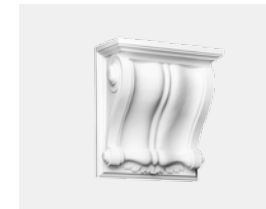

B409 LUXXUS

30 x 35 x 17,5 cm
Purotouch[®]



B410 LUXXUS

19,3 x 49 x 15,8 cm
Purotouch[®]



B413 LUXXUS

16,5 x 22,7 x 8,5 cm
Purotouch[®]



B414 LUXXUS

10,1 x 22,5 x 7,2 cm
Purotouch[®]

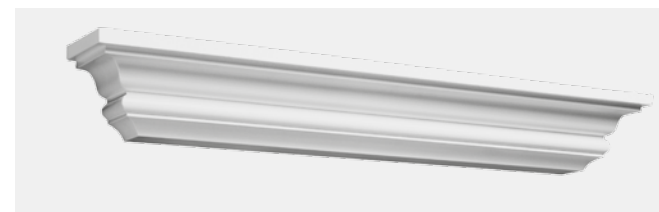

B417 LUXXUS

90,6 x 12,5 x 14 cm
Purotouch[®]



GB02 LUXXUS

7 x 40 x 49 cm
Duropolymer[®]



GB03 LUXXUS

7 x 63 x 58 cm
Duropolymer[®]



GB04 LUXXUS

5 x 74,5 x 77 cm
Duropolymer[®]



TF02 LUXXUS

7,7 x 12 x 10,5 cm
Duropolymer[®]



GB02 - GB03 - GB04 - TF02





Collanti e Accessori
Adezivi si Accesorii
Adhesives and Accessories
Lepidla a příslušenství
Colas e acessórios



DecoFix Pro



FDP500 310ml
> 7 - 8m
FDP600 4200ml
> 65 - 110m

- it** Colla acrilica ultra forte per superfici porose e per l'applicazione all'interno
- Colla acrilica a base d'acqua, forte
 - Incollaggio a lunga durata tra le cornici ed il muro e/o il soffitto
 - Rimuovere l'eccesso con una spugna o uno straccio umidi
 - Tenere il prodotto al riparo dal gelo
 - Può essere verniciato dopo completa asciugatura (min. 24 ore)

DecoFix Hydro



FDP700 290ml
> 7 - 8 m

- Colla a base di polimeri MS extra forte per l'applicazione all'esterno, superfici non porose (piastrelle, vetro, ...) e ambienti umidi**
- Rimuovere l'eccesso con una soluzione saponata
 - Può essere verniciato dopo completa asciugatura (min. 24 ore)

DecoFix Extra



FX200 310ml
> 80m
FX210 80ml
> 20m

- Saldante a base di poliuretano da utilizzare per saldare le giunte delle cornici**
- Rimuovere l'eccesso di saldante prima dell'indurimento (massimo 1 ora e ripetere dopo 2-3 ore)
 - Pulire con acetone o altro diluente sintetico
 - Può essere verniciato dopo 24 ore
 - Un tasso di umidità più alto può accelerare il tempo di asciugatura

**GARANZIA COMPLETA SOLO CON
COLLANTE DECOFIX**

**GARANTIA COMPLETA DACA SE
FOLOSESTE DECOFIX.**

**ONLY FULL
GUARANTEE WITH
DECOFIX**

**PLNÁ ZÁRUKA POUZE S
LEPIDLEM DECOFIX**

**GARANTIA COMPLETA APENAS COM A
UTILIZAÇÃO DAS COLAS DECOFIX**

- PO** Adeziv pentru o instalare foarte puternică pe suprafețe poroase și aplicatii la interior.
- Puternic, silicon acrilic pe baza de apă.
 - Lipire de lungă durată între profile și pereți și/sau tavan.
 - Se îndepărtează cu un burete umed sau o cârpă. A se feri de îngheț.
 - Vopsirea se face după întărire (min. 24h).

- Silicon MS polimer foarte puternic pentru instalarea la exterior, suprafețe non-poroase (gresie, sticlă, ...) și medii umede.**
- Se îndepărtează cu soluție de săpun.
 - Vopsirea se face după întărire (min. 24h)

- Silicon polyurethane pentru imbinările dintre profile.**
- Se îndepărtează excesul de silicon înainte de întărire (max. 1h și se repetă după 2-3h).
 - Se curată cu acetona sau diluant. Vopsirea se face după 24h.
 - Cu cât mediul este mai umed, cu atât uscarea se face mai repede.

- en** Extra strong installation adhesive for porous surfaces and interior applications
- Strong, water-based acrylic glue
 - Long-lasting seal between mouldings and the wall and/or ceiling
 - Remove with humid sponge or cloth
 - Should be kept frost free
 - Paintable after hardening (min. 24 hours)

- Extra strong MS polymer glue for exterior applications, non-porous (tiles, glass, ...) surfaces and damp environments**
- Remove with soap solution
 - Paintable after hardening (min. 24 hours)

- Polyurethane-based glue to seam joints between mouldings**
- Remove excess glue before hardening (max. 1 hour and repeat after 2-3 hours)
 - Clean with acetone or Synth Thinner
 - Can be painted after 24 hrs
 - The more humidity, the faster the drying time

- es** Mismoádně silné montážní lepidlo pro porézní povrchy a pro použití v interiéru
- Silné akrylátové lepidlo na vodní bázi
 - Dlouhodobé spojení mezi lištou a stěnou nebo stropem
 - Odstranění pomocí navlhčené houbovité nebo hadříku
 - Chraňte před mrazem
 - Po zatvrdnutí přetřítelné (min. za 24 hodin)

- Mimoádně silné polymerové lepidlo pro použití v exteriéru, pro neporézní povrchy (dlaždice, sklo...) a vlhké prostředí**
- Odstranění mýdlovým roztokem
 - Po zatvrdnutí přetřítelné (min. za 24 hodin)

- Polyuretanové lepidlo pro pevné spojení mezi lištami**
- Po zatvrdnutí přebytečné lepidlo odstraňte (max. za 1 hodinu a znovu za 2-3 hodiny)
 - Čistěte acetonem nebo syntetickým ředidlem
 - Lze přetřít po 24 hodinách
 - Vyšší vlhkost urychluje schnutí

- pt** Cola Extra Forte para superficies porosas e aplicações interiores
- Cola acrílica de base aquosa
 - Selagem de longa duração entre sancas e parede e/ou tecto
 - Fácil remoção dos resíduos da cola com uma esponja ou pano húmido
 - Deve ser guardado em ambiente seco
 - Pintável após endurecimento (min. 24 horas)

- Extra forte, cola á base de MS polímero, para aplicações no exterior, superficies não porosas (Cerâmica, vidro, ...) e ambientes húmidos**
- Removível com uma solução de água e sabão
 - Pintável após endurecimento (min. 24 horas)

- Cola á base de poliuretano para união de juntas entre perfis**
- Remove o excesso de cola antes de endurecer (máx. 1 hora e repita 2-3 horas depois)
 - Limpe com acetona ou diluente sintético
 - Pode ser pintado após 24 horas
 - Quanto mais humidade mais rápido será o tempo de secagem



Per interni, superfici porose, ambienti non umidi
Suprafete la interior, poroase si uscate
Interior, porous and dry surface
Pro použití v interiéru, porézní a suchý povrch
Interior, superficies secas e porosas



DecoFix Pro

Incollaggio su muri e soffitti
Lipirea de tavan si perete
Gluing on wall and ceiling
Lepení na stěnách a stropěch
Colagem na parede e no teto

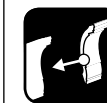

DecoFix Extra

Giunte
Imbinari
Joints
Spoje
Juntas



Per Basixx: utilizzare DecoFix Pro per le giunte
Pentru Basixx: folosiți DecoFix Pro pentru imbinari
For Basixx: use DecoFix Pro for joints
Pro kolekci Basixx: Na spoje použijte lepidlo DecoFix Pro.
Para Basixx: utilize DecoFix Pro para as juntas



Per ambienti umidi, superfici non porose, posa all'esterno
Suprafete la exterior, non-poroase si umede
Exterior, non-porous and humid surface
Pro použití v exteriéru, neporézní a vlhký povrch
Exterior, ambientes húmidos e instalações em superficies não porosas



DecoFix Hydro

Incollaggio su muri e soffitti
Lipirea de tavan si perete
Gluing on wall and ceiling
Lepení na stěnách a stropěch
Colagem na parede e no teto



Accessori / Accesorii / Accessories / Příslušenství / Acessórios



FDP100



FB15

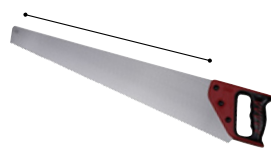

FB14
A: 60 cm

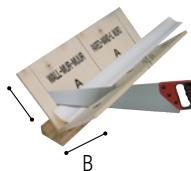

FB300
A: 29,7 cm - B: 29,1cm

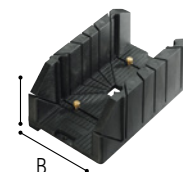

FB13
A: 12,5 cm - B: 15,5 cm



FB10
A: 27,5 cm - B: 22 cm

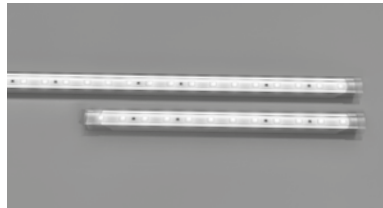

LOW LUMEN LED BARS

IL004-001 26 x 2 x 1,5 cm 
IL004-002 114,5 x 2 x 1,5 cm

IP50 - 24V
 warm white 2700-2900K
 2 clips incl.
 CRI: 80
 Light output / meter: +/- 100Lm
 Power / meter: +/- 4W
 Life span: +/- 30.000 hours



HIGH LUMEN LED BARS

IL004-006 26 x 2 x 1,5 cm 
IL004-007 114,5 x 2 x 1,5 cm

IP50 - 24V
 warm white 2700-2900K
 2 clips incl.
 CRI: 80
 Light output / meter: +/- 500Lm
 Power / meter: +/- 10.5W
 Life span: +/- 30.000 hours



LED DRIVER

IL004-013 30,5 x 3 x 1,7 cm
 IP20 - 60W
 24VDC - 200-240VAC
 Class II (double insulated)



1-10V DIMMABLE MODULE

IL004-009 16 x 4,7 x 2,2 cm
 IP40 - 240W (<10A)
 12-24VDC

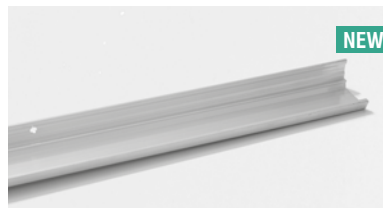

ALUMINIUM SUPPORT

IL004-008 
 200 x 2 x 3 cm

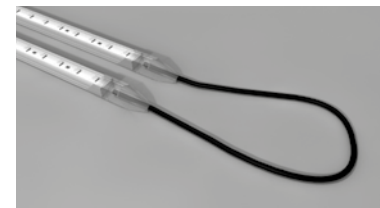

CABLES TWO CONNECTIONS

IL004-004 12,5 cm
IL004-005 100 cm



CABLE ONE CONNECTION

IL004-010 100 cm
 DRIVER > LED BAR

LED BARS

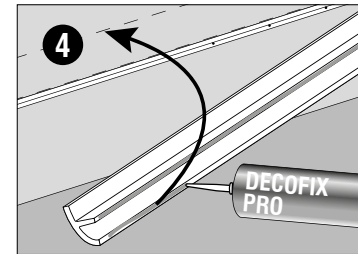
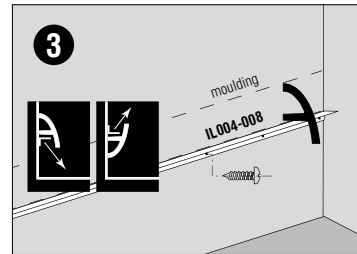
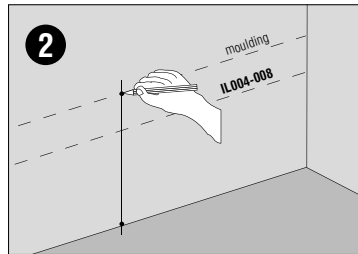
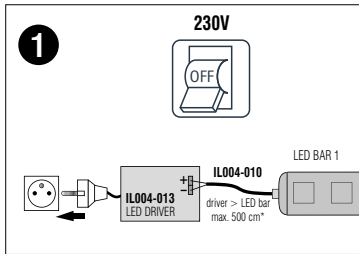

5

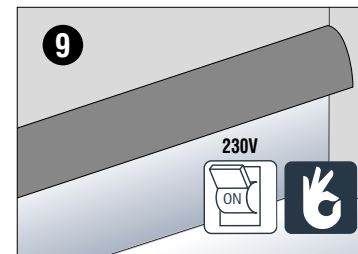
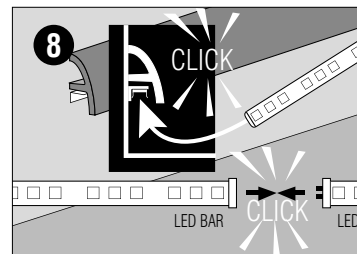
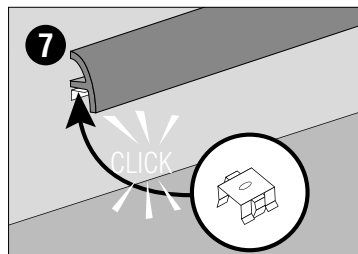
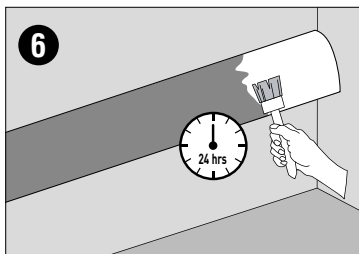



it

- Più di 40 anni d'esperienza internazionale
- Possibilità di corsi di formazione
- Sul sito www.oracdecor.com sono disponibili i disegni in formato 2D e 3D
- Partners internazionali dedicati
- Servizio di campionatura semplice ed efficace
- Consigli professionali per aiutarvi nei vostri progetti

ro

- Mai mult de 40ani de experienta internationala.
- Training de instalare pe site si la Orac.
- Fisiere 2D si 3D pe www.oracdecor.com.
- Parteneri dedicati din toata lumea.
Un serviciu simplu si eficient pentru profesionisti.
- Sfaturi tehnice din partea expertilor nostri.

en

- More than 40 years of international expertise
- In house and on site installation training available
- 2D and 3D files available on www.oracdecor.com
- Dedicated worldwide partners
- Sample service for professionals
- Technical advice from our in house experts

cz

- Více než 40 let mezinárodní působnosti v oboru
- Poskytujeme interní i externí školení
- 2D a 3D soubory dostupné na www.oracdecor.com
- Specializovaní partneři na celém světě
- Vzorčky pro profesionály
- Technické poradenství od našich odborníků

pt

- Mais de 40 anos de experiência internacional
- Instruções personalizadas da instalação dos nossos productos da ORAC e no site
- Arquivos 2D e 3D disponiveis no site www.oracdecor.com
- Parceiros globalmente dedicados
- Servico de amostras para profissionais, simples e eficaz
- Aconselhamento profissional desde o inicio do seu projeto



it

I prodotti Ulf Moritz, Luxxus e Axxent possono essere applicati all'esterno.

Per le istruzioni d'installazione, vedere pag. 150 - 151.

Questi prodotti devono essere protetti con una pittura specifica per l'esterno.

ro

Toate produsele Ulf Moritz, Luxxus ai Axxent pot fi instalate si la exterior.

Instructiuni de instalare la pagina 150-151.

Vopsirea se face cu o vopsea speciala pentru exterior.

en

All Ulf Moritz, Luxxus and Axxent products can be used for exterior applications.

Gluing instructions on pg. 150 - 151.

The products have to be painted with a special coating for outside use.

cz

Všechny produkty z kolekci Ulf Moritz, Luxxus a Axxent je možné použít pro aplikace v exteriéru.

Pokyny pro lepení najdete na str. 150–151.

Produkty je nutné natřít speciálním nátěrem pro venkovní použití.

pt

Todos os produtos Ulf Moritz, Luxxus e Axxent podem ser utilizados em aplicações exteriores.

Instruções de instalação na pág. 150-151.

Os produtos devem ser pintados com uma tinta especial para uso exterior.

**CONTATTATECI PER OGNI
CONSIGLIO**

**CONTACTATI-NE PENTRU MAI
MULTE INFORMATII**

CONTACT US FOR ADVISE

**POKUD POTŘEBUJETE PORADIT,
KONTAKTUJTE NÁS**

**CONTACTE-NOS PARA MAIS
INFORMAÇÕES**

Angolo interno | Colt interior | Inner corner | Vnitřní roh | Ângulo interior

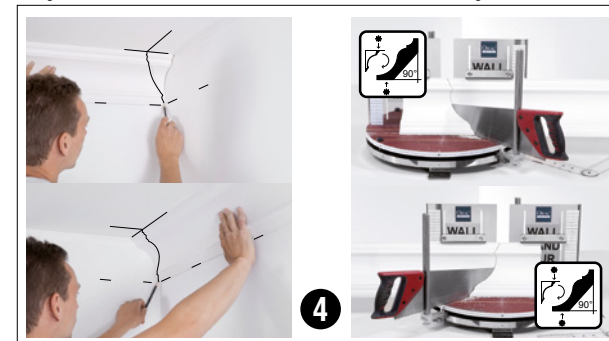
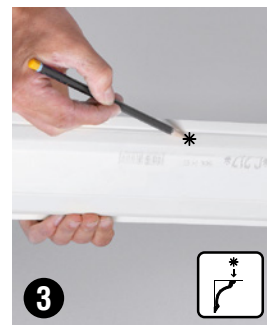
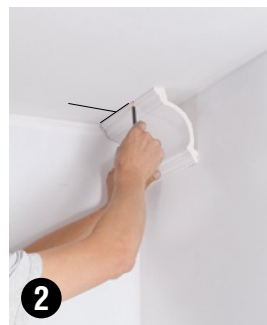
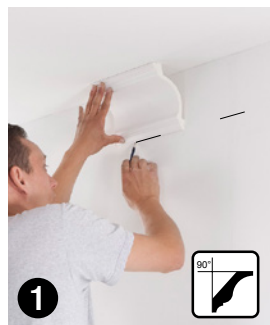

Angolo esterno | Colt exterior | Outer corner | Vnější roh | Canto exterior

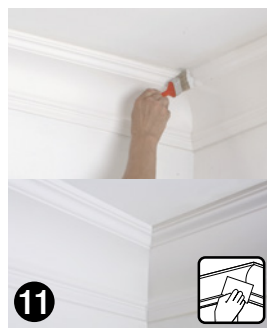
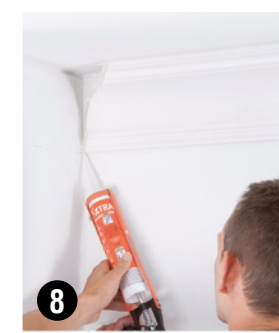
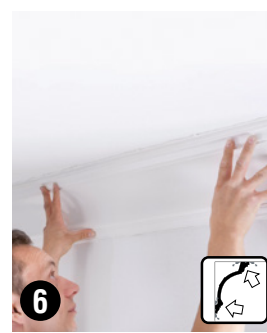
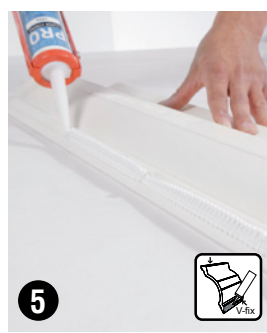
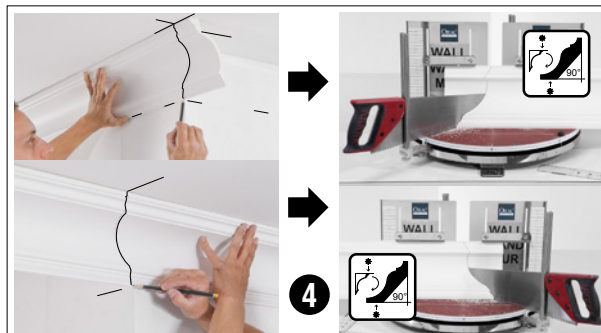

Chiusura
Opriri
Stop mitre
Seříznutý konec
Esquadria



Parole chiave

Accessori	148-153
Adesivi	150,151
Angoli per cornici	109, 110
Applicazioni esterne	155
Attrezzi	151
Axxent	62
Basi	128, 143-145
Basixx	62
Battiscopa	112-117
Boiserie	108, 131
Byblos	134, 135
Camini Decorativi	133
Capitelli	143-145
Collanti	150, 151
Colonne	143-145
Consoles	147
Contorni Porta	128-129
Cornici Flessibili	98, 111, 117
Cornici Parete	100-111
Cornici Soffitto	80-99
Cupole	140
DecoFix Extra	150, 151
DecoFix Hydro	150, 151
DecoFix Pro	150, 151
Decorazione Camini	133
Durofoam®	63
Duropolymer®	63
Elementi Decorativi	141-143
Flex	98, 111, 117
Frontoni	132
Garanzia	150, 160
Illuminazione Indiretta	118-124, 152-153
Installazione	156
Lambris	108,131
Lampade a muro	135
LED	152, 153
Luxxus	62
Mensole	147
Nicchie	133
Norme anti-incendio	160
Pannelli	130
Pannelli per porta	130
Pilastr	146
Poliuretano	63
Progetti	154
Purotouch®	63
Rosoni	136-139
Saldante	150, 151
Seghe	151
Squadre tagliacornici	151
Trasformatore	152, 153
Ulf Moritz for Orac Decor®	62, 64-79
Variomatic	151
Zoccolini	112-117

Cuvinte cheie

Accesorii	148-153
Adezivi	105,151
Ancadramele usi	128-129
Aplicatii la exterior	155
Axxent	62
Basixx	62
Biblos	134,135
Brauri	100-111
Brauri	130
Brauri de coit	109, 110
Capiteluri	143-145
Coloane	143-145
Console	147
Contract	154
Cornise	80-99
Cutii	151
DecoFix Extra	150, 151
DecoFix Hydro	150, 151
DecoFix Pro	150, 151
Domuri	140
Driver	152, 153
Durofoam®	63
Duropolymer®	63
Elemente decorative	141-143
Fierastrau	151
Fixtures	135
Garantie	150, 160
Illuminat indirect	118-124, 152-153
Instalare	156
Lambriu	108,131
LED	152, 153
Luxxus	62
Module	152, 153
Nise	133
Orac Flex	98, 111, 117
Paneluri usi	130
Piese decorative	133
Pilastru	146
Pistol pentru silicon	151
Pliinte	112-117
Polyurethane	63
Postament	132
Profile flexibile	98, 111, 117
Purotouch®	63
Rozete	136-139
Silicon	150, 151
Socluri	128, 143-145
Ulf Moritz pentru Orac Decor®	62, 64-79
Variomatic	151

Key words

Accessories	148-153
Adhesive	105, 151
Axxent	62
Basixx	62
Byblos	134, 135
Capitals	143-145
Ceiling roses	136-139
Ceiling tiles	140
Columns	143-145
Contract	154
Corbels	147
Cornice mouldings	80-99
Deco elements	141-143
DecoFix Extra	150, 151
DecoFix Hydro	150, 151
DecoFix Pro	150, 151
Decorative mantel pieces	133
Dimming module	152, 153
Domes	140
Door frames	128-129
Door panels	130
Driver	152, 153
Durofoam®	63
Duropolymer®	63
Exterior applications	155
Fire retardant standards	160
Fixtures	135
Flexible mouldings	98, 111, 117
Glue	150, 151
Glue pistol	151
Guarantee	150, 160
Indirect lighting	118-124, 152-153
Installation	156
LED bars	152, 153
Luxxus	62
Mitre boxes	151
Niches	133
Orac Flex	98, 111, 117
Panel mouldings	100-111
Panelling	130
Panels moulding corners	109, 110
Pediments	132
Pilasters	146
Polyurethane	63
Purotouch®	63
Saw	151
Skirting boards	112-117
Socles	128, 143-145
Ulf Moritz for Orac Decor®	62, 64-79
Variomatic	151
Wainscoting	108,131

Klíčová slova

Aplikace v exteriéru	155
Axxent	62
Basixx	62
Byblos	134, 135
DecoFix Extra	150, 151
DecoFix Hydro	150, 151
DecoFix Pro	150, 151
Dekoratívni křbové římky	133
Dekoratívni prvky	141-143
Durofoam®	63
Duropolymer®	63
Dveřní panely	130
Dveřní rámy	128-129
Flexibilní lišty	98, 111, 117
Hlavice	143-145
Instalace	156
Konzole	147
Kopule	140
LED panely	152, 153
Lemovací lišty	100-111
Lepicí pistole	151
Lepidlo	105, 151
Luxxus	150, 151
Luxxus	62
Montážní nářadí	135
Nástěnné obklady	108,131
Nepřímé osvětlení	118-124, 152-153
Niky	133
Normy týkající se retardérů hoření	160
Obklady	130
Orac ohebné	98, 111, 117
Pila	151
Pilastry	146
Podlahové lišty	112-117
Pokosnice	151
Polyuretan	63
Průslušenství	148-153
Purotouch®	63
Římky	132
Rohy s lemovacími lištami	109, 110
Rozety	136-139
Sloupy	143-145
Smluvní spolupráce	154
Sokly	128, 143-145
Stmivací modul	152, 153
Stropní kazety	140
Stropní lišty	80-99
Trafo	152, 153
Ulf Moritz pro Orac Decor®	62, 64-79
Variomatic	151
Záruka	150, 160

Palavras-chave

Acessórios	148-153
Aplicações no exterior	155
Aplicações de parede	135
Axxent	62
Barras de Led	152,153
Basixx	62
Byblos	134, 135
Cola para instalação	151
Colunas	143-145
Colunas	143-145
Cúpula	140
Decofix Extra	150, 151
Decofix Hydro	150, 151
DecoFix Pro	150, 151
Durofoam	63
Duropolymer®	63
Elementos decorativos	141-143
Encadernamento de porta	129
Esquadria	151
Esquadria	110
Frontões	132
Garantia	150, 160
Iluminação indireta	118-124, 152-153
Instalação	156
Lambrim	108, 131
Lareira decorativa	133
Luxous	62
Nichos	133
Normas anti fogo	160
Orac Flex	98, 111, 117
Painéis	130
Painéis de porta	130
Peanhas	147
Pedestais	128,143-145
Perfis	100-111
Pistola para colas	151
Placas de teto	140
Poliuretano	63
Projetos	154
Purotouch®	63
Rodapés	112-117
Rosetas	136-139
Sancas	80-99
Sancas Flexíveis	98, 111, 117
Serrote	151
Transformador	152,153
Ulf Moritz for Orac Decor®	62, 64-79
Variete - Variateur	152,153
Variomatic	151

B		C305 + C211	83	C370	67, 90	CX107	96	D		F	
B401	147	C305 + C213	83	C371	66, 125	CX108	94	D120	132	F10	140
B404	147	C307	90	C372	66, 125	CX109 CX109F	94	D140	132	F11	140
B408	147	C307 + C307A	90	C373 C373F	68, 123	CX110 CX110F	94	D161	132	F12	140
B409	147	C308 C308F	91	C374 C374F	66, 123	CX111	93	D170	132	F30	130, 140
B410	147	C321 C321F	85	C400	83	CX112	94	D200	128, 141	F31	140
B413	147	C322 C322F	83	C402 C402F	85	CX115	93	D210	128, 141	FB10	151
B414	147	C331 C331F	83	C422	89	CX123	95	D300	128, 134	FB13	151
B417	147	C332	85, 91	C602 C602F	83	CX124 CX124F	94	D310	128, 134	FB14	151
		C333 C333F	86	C900	89, 125	CX126	95	D320	146	FB15	151
		C334 C334F	88	C901 C901F	88, 125	CX127 CX127F	96	D330LR	128	FB300	151
		C335	91, 160	C902 C902F	85, 125	CX128	96	D400	132	FDP100	151
		C336	91	C990	88, 90	CX129	96	D401	132	FDP500	150, 151
		C337	89	C990 + 2x P9900	88, 90	CX132 CX132F	92, 114	D402	132	FDP600	150, 151
		C338	89	C990 + P9900	88, 90	CX133	93, 114	D500	130	FDP700	150, 151
		C338A	89	C990 + P9901	88, 90	CX134	108	D503	130	FX200	150, 151
		C338B	59, 89	C991	70, 86, 87, 125	CX136	95	D504	130	FX210	150, 151
		C339 C339F	87	C991 + 2x P9900	86, 87	CX141	95	D506	130		
		C340	86, 91	C991 + P9900	86, 87	CX142	95	D507	130		
		C341 C341F	84	CB500	97	CX143	95	D62	136, 141	G	
		C342	87	CB501	97	CX148 CX148F	93	DX119-2300	104, 128	G40	141
		C343	90	CB502	97	CX149	93	DX121-2300	104, 128	G42	141
		C344	91	CB503	97	CX150	93	DX157-2300	92, 107, 114, 129	G70	72, 142
		C351	120	CB510	97	CX151	94	DX159-2300	92, 107, 114, 129	G71	71, 143
		C352	120	CB511	97	CX152	94	DX162-2300	92, 106, 114, 129	G72	72, 73, 142
		C353	82	CB512	97	CX153	94	DX163-2300	92, 107, 115, 129	G73L	72, 142
		C354	82, 99	CB520	97	CX154	93	DX168-2300	92, 107, 116, 129	G73R	72, 142
		C355	82	CB521	97	CX160	92	DX170-2300	105, 128	G74L	72, 142
		C356	82	CB522	97	CX161	92			G74R	72, 142
		C357	120	CB523	97					G75	71, 143
		C358	120	CB530	97					G76	71, 143
		C360	82	CB531	97					G77	72, 138, 142
		C361	121	CX100 CX100F	95					G78	72, 142
		C362	121	CX101	95					GB02	147
		C364	121	CX106	96						

GB03	147	K1132	144	K4131	143	P3071	67, 105	PX114	107	R50	137
GB04	147	K1141	145	K4132	143	P4020 P4020F	102, 109	PX116	106	R52	138
		K1142	144	KIT KX001	128	P4020A	109	PX117	106	R61	137
H		K1151	145	KIT KX003	128	P5020 P5020F	104, 109	PX120 PX120F	106, 110	R64	139
		K1152	144			P5020B	109, 141	PX120A	110	R66	138
H100A	133	K200	135, 146	L		P5020B	109	PX131	106	R70	71, 138
H100B	133	K201	135, 146			P5021 P5021F	102	PX144 PX144F	106	R73	139
H100C	133	K201LR	146	L504	135	P5050	105	PX145	106	R76	138
H101A	133	K202	135, 146	L505	135	P5051	103	PX146	107	R77	138
H101B	133	K2131	145			P6020 P6020F	103	PX147	108, 131		
		K2132	144	M		P7010 P7010F	104	PX164	93, 108	S	
I		K220	146			P7020 P7020F	105	PX169	108, 131		
		K221	146	M9010A	134	P7030 P7030F	104			SX104	116
IL004-001	152, 153	K223	146	M9010B	134	P7040 P7040F	103	R		SX105 SX105F	115
IL004-002	152, 153	K240	146	M9010C	134	P7070 P7070F	103			SX118 SX118F	116
IL004-004	152, 153	K241	146	M9010LR	134	P7080	105	R07	136	SX122	114
IL004-005	152, 153	K250	146			P801C	109	R08	136	SX125	114
IL004-006	152, 153	K251	146	N		P8020 P8020F	103, 109	R09	137	SX137	115
IL004-007	152, 153	K253	146			P8030 P8030F	102, 109	R10	136	SX138	116
IL004-008	152, 153	K254	146	N503	133	P8030C	109	R11	136	SX155 SX155F	115
IL004-009	152, 153	K255	146	N504	133	P8030D	109, 110	R12	136	SX156	116
IL004-010	152, 153	K3001	145	N510	133	P8040 P8040F	104	R13	137	SX165 SX165F	114
IL004-013	152, 153	K3002	144	N520	133	P8050 P8050F	29, 105	R14	137	SX167	116, 122
		K3101	145			P8060 P8060F	102	R17	137		
K		K3102	144	P		P9010 P9010F	104, 128, 134	R18	137	T	
		K3111	145			P9020 P9020F	104	R22	139		
K1001	145	K3112	144	P101A	109	P9040 P9040F	102	R23	139	TF02	147
K1002	144	K3141	145	P1020 P1020F	102, 109	P9050 P9050F	102	R24	139		
K1101	145	K3142	144	P20	109, 141	P9900 P9900F	103	R27	139		
K1102	144	K3151	145	P201A	109	P9901 P9901F	103	R28	138		
K1111	145	K3152	144	P2020 P2020F	102, 109	PB513	97	R31	137		
K1112	144	K3201	145	P21	109, 141	PX102	107	R35	136		
K1121	145	K3202	144	P3020 P3020F	103, 109	PX103 PX103F	106, 110	R38	139		
K1122	144	K4121	143	P3020A	109	PX103A	110	R40	139		
K1131	145	K4122	143	P3070	67, 105	PX113	107	R46	138		

SPECIAL THANKS TO

't Goude Hooft, Intera /Gilbert Comhair - Rabo Bank, MEMO/Harry Karel - The Hamptons, Kissy Vandenplas - Berto , Winny Vangroenweghe - Pand 16, Cheops - Veerle de Niel - Lan Lan, Marisa Gallo - Casa Decor, Beatriz Silveira, Manuel Nuñez y Sergio Moreno, Guillermo Garcia-Hoz, Jean Porsche - Northsea Penthouse, Ann Gryp - House of Porters - Items Knokke - RR Interieur - 't Casteelken - Wildspirit - Sigisbert Engelbosch - Hotel Das Tegernsee - the ORAC team

PHOTOGRAPHY BY

Verne Photography, Jürgen de Witte, www.bartvanleuven.com

REGISTERED CTM DESIGN N°

C335/000995576-0001 - C336/1035273-0001 - C337/1810706-0001 - C338/1978214-0001 - C338A/002341727-0007 - C338B/002341727-0006 - C339/1978214-0002 - C340/1978214-0003 - C341/002524769-0001 - C342/002524769-0002 - C343/002524769-0003 - C344/002524769-0004 - C351/000257464-0003 - C352/000257464-0004 - C353/000257464-0005 - C354/000257464-0006 - C355/000257464-0007 - C356/000257464-0008 - C361/1890526-0001 - C362/1890526-0002 - C363/1890526-0003 - C364/1890526-0004 - C370/2088880-0001 - C371/2088880-0002 - C372/2088880-0003 - C373/002524769-0005 - C374/002524769-0006 - C390/000995576-0002 - C991/002524769-0007 - CB500/1035273-0006 - CB501/1035273-0005 - CB502/1035273-0007 - CB503/1890526-0005 - CB510/1035273-000 - CB511/1035273-0003 - CB512/1890526-0007 - CB523/1035273-0002 - CB530/1890526-0008 - CB531/1890526-0009 - CX160/1790163-001 - CX161/1790163-0002 - D330/002524769-0013 - DX159-2300/1790163-0003 - DX162-2300/1790163-0004 - DX163-2300/1790163-0005 - DX168-2300/002341727-0004 - DX170-2300/002524769-0008 - G70/002158089-0001 - G71/002158089-0002 - G72/002158089-0003 - G73/002158089-0004 - G75/002524769-0009 - G76/002524769-0010 - G77/002524769-0011 - G78/002524769-0012 - P3020A/002341727-0005 - P3070/2088880-0004 - P3071/2088880-0005 - P5050/000257464-0001 - P5051/000257464-0002 - P8050/000995576-0003 - P8060/1810706-0002 - P9900/000995576-0004 - P9901/000995576-0005 - PB513/1890526-0006 - PX147/002341727-0003 - PX164/1790163-0006 - PX169/002341727-0002 - R70/2088880-0006 - SX156/000995576-0006 - SX165/002341727-0001 - SX167/2088880-0007

Guarantee terms and conditions apply if provided installation instructions have been followed to the letter.

Fire retardant standards. In many interiors and projects strict fire regulations are imposed. Therefore, ORAC has implemented a number of solutions depending on the country and its regulations. Please contact us for more information.

The information in this catalogue is without engagement. Changes and discrepancies in sizes or/and shapes against those stated in the catalogue can occur.

This catalogue and the design embodied within are protected by copyright law and international treaties. Unauthorized reproduction of the catalogue, any portion of it or the reproduction of the designs embodied therein may result in severe civil and criminal penalties and will be prosecuted to the maximum. Further legal information can be found on: www.oracdecor.com/nl/disclaimer.

All rights reserved. ©2014, ORAC nv

Concept & Graphics by King of Hearts and Gazeuse.be

Reflecting
your
Imagination

ORAC HEADQUARTERS

NV ORAC SA

Biekorfstraat 32
8400 Ostend, BELGIUM
T +32 (0)59 80 32 52
F +32 (0)59 80 28 10
info@oracdecor.com

ORAC NEDERLAND

T 0800-022 2125
F 0800-022 2138
nederland@oracdecor.com

ORAC FRANCE

T 0800-900 358
F +32 (0)59 80 28 10
france@oracdecor.com

ORAC DEUTSCHLAND

T 0800-181 3694
F +32 (0)59 34 05 24
deutschland@oracdecor.com

ORAC (UK) LTD

City Business Centre
Brighton Road, Unit 8
Horsham RH13 5BB - UK
T +44 1403 240 102
F +44 1403 258 686
uk@oracdecor.com

ORAC SLOVAKIA S.R.O.

Kpt. Nalepku 6
08271 Lipany - SK
T +421 (0)514-891 581
F +421 (0)514-573 595
slovakia@oracdecor.com

ORAC SPAIN

T 900 99 32 89
F +32 (0)59 80 28 10
espana@oracdecor.com